

INFORMATION ON SAFETY

The following indications have been used to identify the safety messages in this manual:

! WARNING! This indication is used in the safety messages for risks that, unless avoided, can cause malfunctioning or damage to property or persons.

NAVIGATION

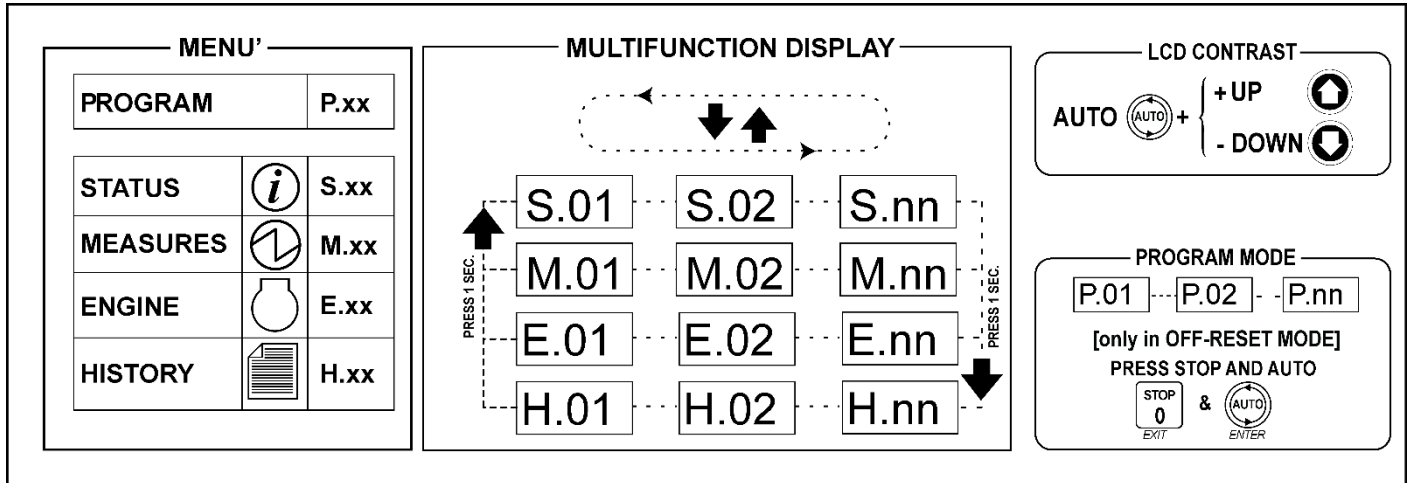

This area, which is composed by a display and the buttons, allows the visualization of the configuration parameters, the plant status, the electrical measures, the engine analogue and digital measures, the digital IN/OUT signals acquired and the historic visualization of the events and the measures.

The navigation is organized in menus and pages.

The **UP** button pressed at least for 1 second, activates the navigation menu. The **UP** and **DOWN** buttons to move between the icons of this menu. Pressing the **DOWN** button at least for 1 second the icon selected, you will trigger the display of the selected menu with its windows. The **UP** and **DOWN** buttons allow to move through pages of the same menu. The **STOP** and **AUTO** buttons, pressed simultaneously in the **OFF-RESET** mode, allow you to activate the **PROGRAM** menu to view / edit the parameters of the device.

The **STOP** button allow to return to the previous menu, to cancel an adjustment in progress. The **AUTO** button together with other buttons allows to increase up to x10 the movement of values or to vary the display light. Depending on the environmental lighting conditions, a contrast adjustment may be required in order to view the display correctly. Press the buttons sequence **AUTO + DOWN** to decrease the contrast and **AUTO + UP** to increase it.

OPERATION

This area, composed by buttons and leds, allows the choice of the operating mode of the plant: **PROGRAM-OFF/RESET**, **AUTOMATIC-TEST**, **MANUAL**.

To modify the operating mode it is necessary to press the **STOP(OFF-RESET)**, **AUTO(AUTOMATIC)** or **START(MANUAL)** buttons for some seconds. The led on, in relation to the symbols, indicates the current operating mode on the device.

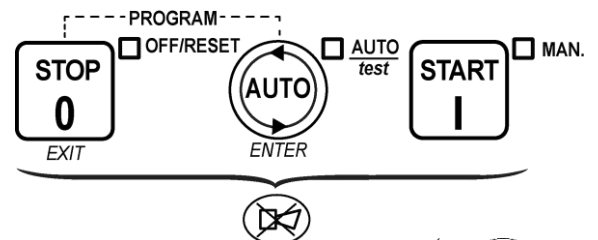

- **PROGRAM** (Engine Stopped) By means of the **STOP** and **AUTO** buttons pressed together, it is possible to enter the configuration menu and adjust the available parameters (some parameters may require a password).
- **OFF/RESET** (Engine Stopped): In this mode, the control and switching commands are disabled. In this status, no faults (warning/alarm) are revealed.
- **MAN** (Engine Started/Stopped): In this mode, the control commands are enabled. It is possible to start the engine by pressing the **START** button and stop the engine with the **STOP** button. With engine started and electrical measures within tolerance, it is possible use pre-configured **MCB/GCB** digital inputs to switch the

Loads between the **Mains** and the **Genset** and vice versa.



WARNING! Each switching command, even in case of Mains live, corresponds to a temporary blackout due to the circuit breakers/changeover switches opening.

- **AUTO** (Engine Started/Stopped automatically): In this mode, in case of **Mains** failure, the device starts the genset (**START** command), control the circuit breaker (**MCB/GCB**) to switch the **Loads** from the **Mains** to the **Genset**, monitor the electrical measures to determine when the **Mains** is back. When the **Mains** is back, the device command the **MCB** and **GCB** circuit breakers to supply the **Loads** by the **Mains**.

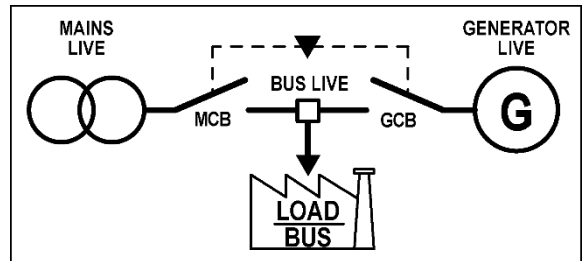

It carries out the engine cooling for the time set and, once it is over, it stops it (**STOP** command). That is carried out autonomously, so the operator doesn't have to intervene manually.

PARAMETERS CONFIGURATION



WARNING! Assigning an incorrect value to one or more parameters can cause malfunctioning or damage to things and/or people. The parameters changes must be carried out only by skilled personal. The parameters can be protected by password (see par. Access codes).

In order to adjust the parameters, it is necessary to enter the **PROGRAMMING** menu (page P.XX). The access to the parameters programming mode can be protected by **3** different **PASSWORD** levels (**it depends on the device**), which are listed in order of priority.

1. **Manufacturer Password**
2. **Installer Password**
3. **User Password**

If the password is lost, you can reconfigure it using a higher level password. Contact the technical support if the **MANUFACTURER** password is lost.

Enter the authentication password on page 1.1.1. Authentication To access, enter the various menus and submenus following the path: **PROGRAMMING**, 1. **SYSTEM**, 1.1 **Security**, 1.1.1. **Authentication**.

The page (000-Access Code) of the Security 1/01 menu requires the setting of the access code if one or more passwords have been assigned. No password is assigned if equal to 0.

In programming mode, if the page for changing the password isn't displayed when the Password is entered, press **STOP** to return to the previous menu and try to open the page again.

The set access code remains valid for about 10 minutes after programming has been completed. After that, you must enter the access code to access the programming mode again.

Setting the parameters

In the **PROGRAMMING** page, enter the submenus with the **AUTO** button.

Use the **UP** and **DOWN** buttons to select the submenu required and the **AUTO** button to access it. Select the submenu or the parameter required with the **UP** and **DOWN** buttons. By pressing **AUTO**, you enable the adjustment of the parameter value that is signalled by the square brackets [..] flashing. Use the **UP** and **DOWN** buttons to change the value and press **AUTO** to confirm or **STOP** to cancel the change.

If the square brackets are replaced by the symbols < >, it means that the change of the parameter value is not allowed. This can happen for lack of Password authorizations or in case you are trying to change a parameter in a mode that is not allowed. Press **STOP** to exit the programming menu.

Protections and alarms parameters

Protections and alarms can be configured using dedicated variables. Usually, the intervention time related to the protection can be configured too.

In order to deactivate the protection, the acquisition time must be set to 0 (zero).

MAIN DEFAULT PARAMETERS

Description	U.M.	Value	Description	U.M.	Value
SYSTEM			Maximum current delay	s	10
Maker password		0	Short circuit threshold	%	500
System password		0	Short circuit delay	s	0.5
User password		0	Power reverse threshold	%	10.0
Plant type		1-SSB	Power reverse delay	s	10
MAINS			Over speed (from frequency) threshold	%	120.0

Description	U.M.	Value	Description	U.M.	Value
Mains nominal voltage	V	400	Over speed (from frequency) delay	s	0.5
Mains number of phases		3	Low power threshold	%	0.0
Mains voltage hysteresis	%	2.5	Low power delay	s	60
Mains low voltage threshold	%	80.0	High power threshold	%	0.0
Mains high voltage threshold	%	110.0	High power delay	s	3
Mains presence delay	s	30	ENGINE		
Mains fault delay	s	2	Engine type		0
Mains low frequency threshold	%	90.0	Can-Bus command level		0
Mains high frequency threshold	%	110.0	Action on Can-Bus fault		1
Mains voltages unbalance threshold	%	10.0	Engine nominal power	kW	0
Timing for MCB opening		0	Rpm/Hz ratio	rpm/Hz	0
GENERATOR			Starter pulse duration	s	5
Generator nominal voltage	V	400	Number of crank attempts		3
Generator number of phases		3	Time between two crank attempts	s	5
Generator nominal frequency	Hz	50	Stop pulse duration	s	20
Generator voltage hysteresis	%	2.5	Stop cycle duration	s	20
Generator nominal power	kVA	0	Cooling cycle duration	s	45
Delay before supply	s	5	Analogue input 1 function		100
Contactors swap delay	s	2	Oil pressure sensor type		0
Minimum voltage threshold	%	75.0	Coolant temperature sensor type		0
Minimum voltage delay	s	3	Fuel level sensor type		0
Maximum voltage threshold	%	112.5	High coolant temperature threshold	°C	92
Maximum voltage delay	s	3	High coolant temperature delay	s	2
Minimum frequency threshold	%	90.0	Maximum coolant temperature threshold	°C	110
Minimum frequency delay	s	5	Maximum coolant temperature delay	s	2
Maximum frequency threshold	%	110.0	Low oil pressure threshold	Bar	1.5
Maximum frequency delay	s	5	Low oil pressure delay	s	2
Maximum current threshold	%	90.0	Minimum oil pressure threshold	Bar	1.2
Maximum current delay	s	10	Minimum oil pressure delay	s	2
Short circuit threshold	%	500	High fuel level threshold	%	90
Short circuit delay	s	0.5	High fuel level delay	s	2
Power reverse threshold	%	10.0	Low fuel level threshold	%	10
Power reverse delay	s	10	Low fuel level delay	s	2
Voltages unbalance threshold	%	2.5	Minimum fuel level threshold	%	5
Voltages unbalance delay	s	0	Minimum fuel level delay	s	20
Required phases sequence		0	Belt break delay (engine's battery-charger failure)	s	20
Action on wrong phases sequence		1	Low coolant temperature threshold	°C	10
Loss of excitation threshold	kvar	0	Low coolant temperature delay	s	0
Loss of excitation delay	s	0	Coolant heating activation threshold	°C	0
Action on maximum current/short circuit		8	Coolant heating deactivation threshold	°C	0
Maximum power threshold	%	100.0	Action on belt break		8
Maximum power delay	s	0	Fuel pump mode		0
C.T. primary.	A	5	Fuel pump start threshold	%	15
Action on maximum power		1	Fuel pump stop threshold	%	80
Currents unbalance threshold	%	5.0	Fuel pump maximum activation time	s	0
Currents unbalance delay	s	0	Delay between solenoid and fuel pump	s	2.0
Maximum current threshold	%	90.0	Fuel pump supply		0

CHARACTERISTICS AND DIMENSIONS

Supply voltage:	7..32Vdc	Operating temperature:	-30°C..+ 70°C
Current consumption	132mA@13.5VCD 110mA @27VDC	External dimensions:	141(L)x113(H)x39(D)mm
Genset rated frequency:	50/60 Hz	Panel cut-out	118(L)x92(H)mm

CONNECTION DIAGRAM

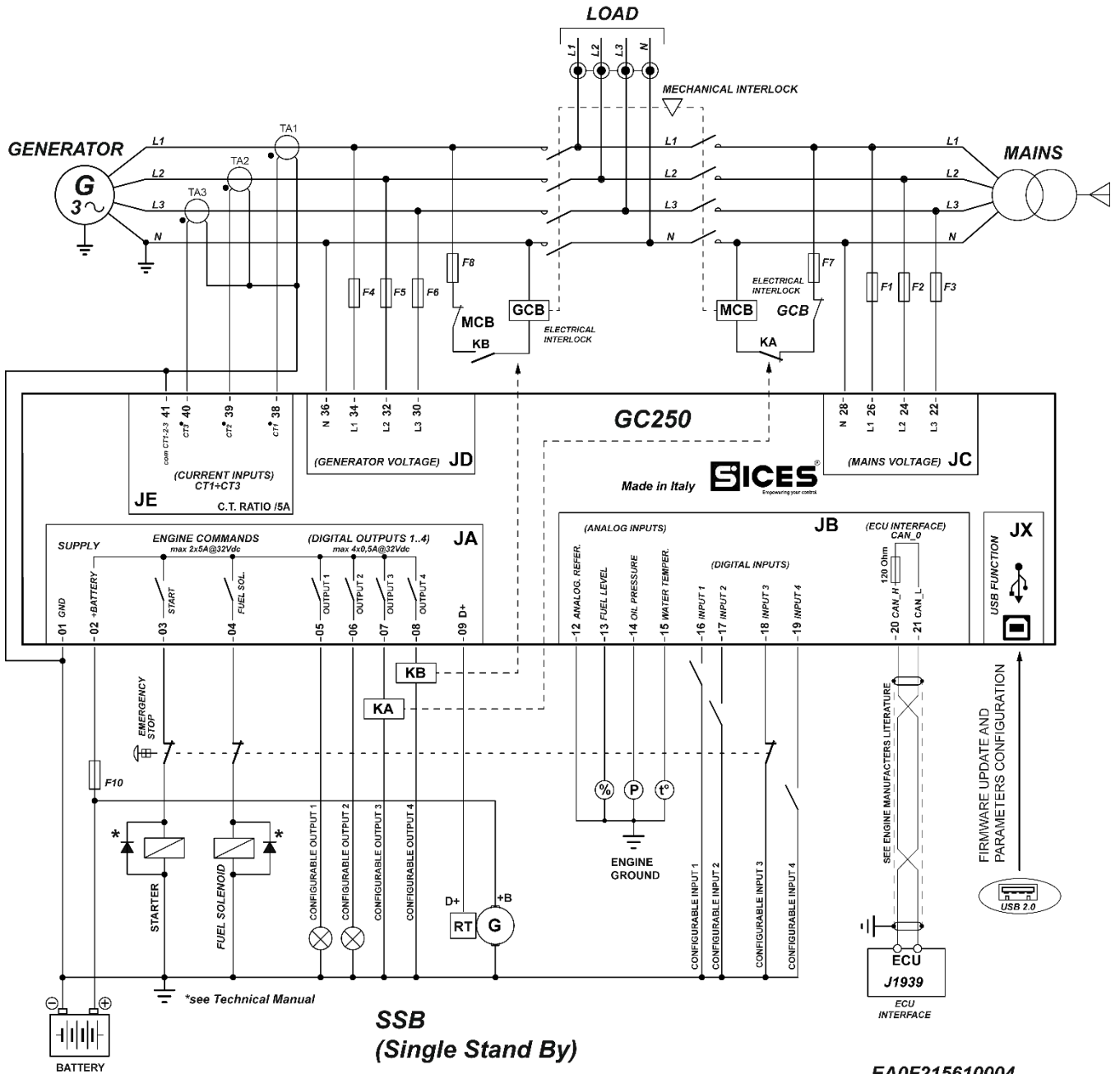

For further information on the device, related to the operation and configuration, please refer to the technical documentation available in the Download Area of the website www.sices.eu.

S.I.C.E.S. SRL
Società Italiana Costruzioni Elettriche Sumirago
 Via Molinello 8B
 21040 - Jerago con Orago (VA) ITALY
 T +39 0331 212941 - F +39 0331 216102
www.sices.eu
sales@sices.eu

SICES BRASIL LTDA
 Avenida Portugal, 1174
 Condomínio Empresarial ONIX
 06696 060 / ITAPEVI (SP)
 T +55 11 4193 2008
www.sicesbrasil.com.br
comercial@sicesbrasil.com.br



EAA0M053801EN