



Technical Manual

GC250

Rev. 13 Date: 08/10/2021
ID Document: EAAM0576
Product: GC250

Revision	Date	Pages	Notes
00	04/11/2016	140	First version of the manual for the version 01.00 of the controller.
01	21/11/2016	141	Paragraphs 3, 7.2, 7.3, 9.5.3.2.1, 9.6 modified
02	10/01/2017	141	Modified par. 3 and 7.4.9.2; Added par. 11:10
03	15/06/2017	141	Modified par. 3, Modified Par. 4.1, Modified Par. 5.11
04	25/07/2017	141	Modified table on par. 5 (page 20); Added par. 11:11
05	11/12/2017	141	Modified table on par. 3 (page 16); Modified par. 11:10
06	23/10/2018	138	Modified table 3; Modified Par. 5.2.1 and 5.2.2 Modified Par. 5.4.1; Modified Par. 5.4.2
07	23/05/2019	143	Modified paragraphs 5.8, 5.6.4, 5.6.3, 5.8.4, 7.4.8.2, 9.1, 10.5, 10.7.48 Added paragraphs 5.8.3, 7.4.8.12 e 7.4.8.13
08	24/10/2019	144	Modified paragraphs 5.6.4, 7.4.7.9, 7.4.8.3, 7.4.8.9, 9.2.3
09	15/04/2021	145	Valid for firmware version 1.09. 1.7, 5.5, 6, 6.1, 6.2, 7.4.6.2, 7.4.6.3, 7.4.6.4, 7.4.6.7, 7.4.7.9, 7.4.7.10, 7.4.7.11, 7.4.8.3, 7.4.8.4, 7.4.8.5, 7.4.8.6, 7.4.8.7, 7.4.8.8, 7.4.8.9, 7.4.8.10, 7.4.8.11, 7.4.9, 7.4.9.7, 8.1, 9.1, 11.1, 11.3, 11.7, 11.11, 11.12
10	29/04/2021	145	Valid for firmware version 1.10. 5.6.4, 10.97, 10.98, 11.12
11	10/09/2021	148	Valid for firmware version 1.12. 5.2, 5.6.4, 7.4.7.1 ... 7.4.7.9, 9.3, 9.5.3.1, 10.08, 10.18, 10.19, 10.99
12	20/09/2021	148	Valid for firmware version 1.13. 5.7.2, 7.4.8.12
13	06/10/2021	150	Valid for firmware version 1.14. 5.2, 5.2.1, 5.2.2, 5.6.1, 5.6.2, 5.6.3, 5.6.4, 5.8.4, 5.9, 7.4.7.1, 7.4.7.2, 7.4.7.3, 7.4.8.11, 7.4.8.12, 7.4.8.13, 7.4.9.2, 8.1, 9.2, 9.6.4.1, 10.7.95, 11.10, 11.13

SOMMARIO

1	Introduction.....	8
1.1	References	8
1.2	Information on safety	8
1.3	Introduction and prerequisites	9
1.4	Notes on the parameter's configuration of the device	9
1.5	Definitions.....	9
1.6	Conventions.....	10
1.7	Software revisions	10
2	Views of the device	11
3	Technical features	12
3.1	Measurement resolution	14
4	Installation	15
4.1	Mounting.....	15
4.2	Wiring	15
5	IN/OUT connections and configuration	16
5.1	Correspondence input/output and their logic functions	17
5.2	Application type	18
5.2.1	Principle connection diagram for Auto Mains Failure applications.....	19
5.2.2	Principle connection diagram for Auto Start application	20
5.3	T.01 and T.02 Device supply	21
5.4	Engine commands outputs T.03 and T.04	22
5.4.1	T.03 START Command for the engine starter motor	22
5.4.2	T.04 FUEL SOLENOID Fuel solenoid command.....	22
5.5	T.09 D+ Energizing and checking the operation of the recharge alternator	24
5.5.1	T.09 D+ Input used as analogue input.....	25
5.5.2	T.09 D+ Input used as analogue input.....	25
5.6	T.05.08 Static digital outputs and command loads switching.....	25
5.6.1	Load switching commands Auto Mains Failure applications.....	26
5.6.2	Load switching commands for Auto Start applications	27
5.6.3	Digital outputs configuration	28
5.6.4	AND/OR logics	31
5.7	Analogue inputs.....	34
5.7.1	T.13, T.14, T.15 - Resistive analogue inputs	34
5.7.2	Configuration and functions of analogue inputs.....	35
5.7.3	Conversion curves.....	38
5.8	Digital inputs	39
5.8.1	T.16...19 DIGITAL INPUTS	39
5.8.2	T.16 D+ Input used as analogue input.....	40
5.8.3	Virtual digital inputs	40
5.8.4	Digital inputs configuration	40
5.9	T.22...T.28 Connection to the mains.....	44
5.9.1	Measurement of the mains neutral	45
5.10	T.30...T.36 Connection to generator.....	45
5.10.1	Measurement of the generator neutral	46
5.11	T.28...T.40 Current transformer connection.....	46

6	Communication resources	47
6.1	USB Connection	47
6.2	RS485 (optional).....	48
6.3	CAN-BUS connections	49
7	Command and indications.....	50
7.1	Front panel GC250	50
7.2	Pushbuttons.....	51
7.3	Indicators	52
7.4	Multifunctional display.....	53
7.4.1	LCD lighting.....	53
7.4.2	Contrast adjustment	53
7.4.3	Mode navigation	53
7.4.4	Structure of display areas.....	54
7.4.5	Top status bar	54
7.4.6	Status information (S.XX).....	56
7.4.7	Electrical measures (M.XX).....	60
7.4.8	Engine measurements (E.XX).....	64
7.4.9	History logs (H.XX).....	72
8	Parameter's programming	79
8.1	Access to programming menu	79
8.1.1	Menu selection	80
8.2	Parameter organization	80
8.2.1	Parameter's selection.....	81
8.2.2	Modify a parameter	81
8.2.3	Set up limits.....	82
8.3	Exit from programming	82
8.4	Loading default values.....	82
8.5	Protection password	83
8.5.1	Password for commands from serial port (USB)	84
9	Operation sequence.....	85
9.1	Operating mode.....	85
9.1.1	Recording of mode in event archive	87
9.1.2	Operation modes and logics AND/OR.....	88
9.2	Mains.....	88
9.2.1	Internal sensor.....	88
9.2.2	External mains sensor.....	92
9.2.3	Mains global status.....	92
9.2.4	Communication and events.....	93
9.3	Generator	93
9.3.1	Genset frequency	94
9.3.2	Genset voltages	95
9.3.3	Generator status.....	96
9.3.4	Communication and events.....	96
9.4	Automatic intervention of the generator inhibited.....	97
9.4.1	Inhibition from contact	97
9.4.2	Inhibition from clock.....	98
9.5	Engine	98
9.5.1	Engine running/stopped status acknowledgement	98

9.5.2	Engine commands.....	99
9.5.3	Command sequence of the engine.....	100
9.5.4	Communication and events.....	103
9.6	Circuit breakers management.....	104
9.6.1	Circuit breakers command.....	104
9.6.2	Acquiring breakers status.....	105
9.6.3	OFF/RESET management logic.....	105
9.6.4	Switching logic in AUTO mode.....	105
9.6.5	MAN or TEST management logic.....	106
9.6.6	Automatic power delivery of the generator inhibited.....	107
9.6.7	Events and signalling related to the breakers.....	107
10	Anomalies	108
10.1	Silencing the horn.....	109
10.2	Acknowledging anomaly.....	109
10.3	Acknowledging anomaly.....	110
10.4	Events and signalling relative to the anomalies.....	110
10.5	Anomalies connected to digital inputs	111
10.6	Anomalies connected to analogue inputs.....	112
10.7	Anomalies list	112
	01 – Minimum generator voltage	112
	02 – Maximum generator voltage	113
	03 – Minimum generator frequency	113
	04 – Maximum generator frequency	113
	05 – Belt break (alternator battery-charger failure)	114
	06 – Maximum current.....	114
	07 – Manual stop while in AUTO	116
	08 – Operating conditions failure	116
	13 – Mains circuit breaker (MCB) not closed	117
	14 – Genset circuit breaker (GCB) not closed	117
	16 – Short circuit on the generator.....	117
	18 – Overspeed (from measure, only for DRIVE applications).	118
	19 – Overspeed (from frequency).....	118
	21 – Engine not stopped.....	118
	22 – Over crank	119
	23 – Mains circuit breaker (MCB) not open	119
	24 – Genset circuit breaker (GCB) not open.....	119
	25 – Minimum fuel level (from contact)	120
	26 – Minimum fuel level (from analogue sensor)	120
	27 – Low fuel level (from contact)	120
	28 – Low fuel level (from analogue sensor)	121
	29 – High fuel level (from contact)	121
	30 – High fuel level (from analogue sensor)	121
	31 – High coolant temperature (from contact)	122
	32 – High coolant temperature (from analogue sensor).....	122
	33 – Maximum coolant temperature (from contact)	122
	34 – Maximum coolant temperature (from analogue sensor)	123
	35 – Maximum oil temperature (from analogue sensor)	123
	37 – Starter battery voltage, low	124
	38 – Starter battery voltage, high.....	124
	39 – Service required.....	124

41 – Minimum oil pressure (from contact).....	125
42 – Minimum oil pressure (from analogue sensor).....	125
43 – Low oil pressure (from contact).....	125
44 – Low oil pressure (from analogue sensor).....	126
48 – Emergency stop.....	126
49 – Maximum power	127
52 – Generator voltages unbalance.....	127
53 – Generator current unbalance	127
54 – High oil temperature (from analogue sensor).....	128
55 – Wrong phases sequence	128
56 – Low generator voltage	129
57 – Clock not valid	129
58 – Low generator frequency	129
59 – High generator voltage	130
60 – High generator frequency	130
62 – Faulty engine CAN-BUS 0 link.....	130
64 – Fuel pump failure	131
65 – Low coolant temperature (from analogue sensor)	131
95 – AdBlue pump failure	131
97 – Communication failure with the ECU	132
98 – Communication failure with the ECU	132
99 – Minimum engine speed (from measure, only for DRIVE applications).....	132
105 – Battery charger failure from CAN-BUS	133
118 – Maximum speed from CAN-BUS	133
132 – High coolant temperature from CAN-BUS	133
134 – Maximum coolant temperature from CAN-BUS	134
135 – Minimum coolant level from CAN-BUS.....	134
136 – Low coolant level from CAN BUS	134
137 – Low battery voltage from CAN BUS.....	134
142 – Minimum oil pressure from CAN BUS.....	135
144 – Low oil pressure from CAN BUS.....	135
158 – High oil temperature from CAN BUS	135
159 – Maximum oil temperature from CAN BUS	136
160 – Water in fuel from CAN BUS.....	136
198 – Warnings cumulative – Yellow lamp from CAN-BUS.....	136
199 – Alarms cumulative – Red lamp from CAN-BUS.....	136
11 Other functions	137
11.1 Fuel pump	137
11.1.1 Use with an analogue level transducer	138
11.1.2 To use this function requires:	138
11.1.3 Level evaluation	139
11.1.4 Automatic pump control	139
11.1.5 Manual pump control.....	139
11.1.6 Protections	139
11.2 Load thresholds.....	140
11.2.1 Low load.....	140
11.2.2 High load.....	140
11.3 Alternative parameters configuration.....	141
11.4 EJP function	142
11.5 Maintenance.....	143

11.5.1	Service hours counter	143
11.6	Counters.....	143
11.6.1	Counters reset	144
11.7	Clock	144
11.7.1	Engine TEST start-up weekly planning.	144
11.7.2	Weekly scheduling of engine operating time intervals.	145
11.8	Non-volatile memory	146
11.9	Plant name	146
11.10	Power saving mode.....	147
11.11	CAN-BUS connection with the ECU of the engines.....	147
11.12	CAN-BUS connection with voltage regulators (AVR)	148
11.13	Pump for AdBlue fluid.....	148
11.13.1	Using an analogue level measurement.....	149
11.13.2	Using a contact level transducer	149
11.13.3	Evaluation of the level.....	150
11.13.4	Automatic pump control	150
11.13.5	Manual pump control.....	150
11.13.6	Protections	150
11.13.7	Signalling	150

1 Introduction

1.1 References

- [1] MECC ALTE EAAM0448xx GC250 parameters chart.
- [2] MECC ALTE EAAM0458xx - BoardPrg4.xx Manual.
- [3] MECC ALTE EAAS0449xx GC250 parameters chart.
- [4] MECC ALTE EAAM0136xx – J1939 Interface Manual.
- [5] CANopen – Cabling and Connector Pin Assignment – CiA Draft Recommendation DR-303-1
- [6] BOSCH CAN Specification – Version 2.0 – 1991, Robert Bosch GmbH.
- [7] MECC ALTE EAAP0457xx USB driver Installation Guide

1.2 Information on safety

Many accidents are caused by poor knowledge and the non-observance of safety regulations, which must be observed when operating and/or servicing the machine.

To prevent accidents, before using or servicing the machine you should read, understand and observe the precautions and warnings in this manual.

This manual contains the following indications:

 **WARNING!** This indication is used in the safety messages of the manual when there are possible danger situations that may cause injuries or death if the danger is not avoided.

This safety messages describe the normal precautions needed to avoid danger. Ignoring these precautions can cause serious damage to property and/or injury to persons.

 **ATTENTION!** This indication is used in the safety messages for dangers that, if not avoided, may cause injuries, damages or malfunctioning.

The message can be also used only for few dangers that may cause damages to things and/or people.

 **INFORMATION!** This term indicates that the message includes useful information for the development of the operation or procedures clarifications.

1.3 Introduction and prerequisites

For the appropriate use of this manual, it is required knowledge of the use and of the installation of generator groups.

WARNING!!!

Every intervention must be carried out by skilled personnel. There are dangerous voltages on the terminals of the device; before carrying out any operation on them, make sure to open the mains and genset circuit breakers or to open the related fuses.

Do not remove or change any connection when the genset is running.

Do not disconnect for any reason the terminals of the current transformers (CT)

Wrong operations on the connections can cause the disconnection of the loads from the mains or the genset.

Please read this manual carefully before using the device.

The device uses a large number of configurable parameters and it is therefore impossible to describe all their possible combinations and effects.

In this document, there isn't a detailed description of all the programming parameters: to this purpose, see documents [1]; these documents are to be considered as part of this manual.

The devices are supplied with a generic “default” configuration; it is at the installer's care to adjust the operating parameters to the specific application.

MECC ALTE carries out a great effort to improve and update its products; therefore, they are subject to both hardware and software modifications without notice. Some of the features described in this manual may therefore differ from those present in your device.

1.4 Notes on the parameter's configuration of the device

Although most of the parameters and features can be accessed and configured by directly operating on the device, **some particular features or configurations, due to their nature, can only be set or changed through the PC program SICES Board Programmer3** (hereinafter called “BoardPrg4”), which can be downloaded for free after registration on the SICES Srl website www.sices.eu www.sices.eu

It simplifies a lot the configuration of the device and its use is strongly suggested. It also allows you to save the current configuration of the device on a file and to reuse it on other identical devices,

The program also allows the configuration, saving or loading of the characteristic curves of non-standard analogue sensors with resistive or live output.

BoardPrg4 is usable on every MECC ALTE device; the connection to the PC is only possible via USB serial port; by connecting the USB port to the PC, the device automatically turns on and it is therefore possible to modify the parameters without other supply sources. For the use of the program, refer to the document [2].

1.5 Definitions

In this document, the word “**ALARM**” is used to indicate a fault that makes the genset operation impossible and causes the automatic and immediate turning off of the engine with emergency procedure (without cooling period).

The word “DEACTIVATION” is used to indicate a fault that makes the genset operation impossible and causes the automatic and immediate turning off of the engine with standard procedure (with cooling period). The controller immediately opens the GCB circuit breaker when this kind of fault arises.

The word “**WARNING**” is used to indicate a fault that requires an operator action but doesn’t require the automatic shut-down of the genset.

The codes that identify functions for input, output, status or other functions are preceded by the following acronyms:

DIF (“Digital Input Function”): the following is a code for the configuration of the digital inputs.

DOF (“Digital Output Function”): the following is a code for the configuration of the digital outputs.

AIF (“ANALOGUE Input Function”): the following is a code for the configuration of the ANALOGUE inputs.

AOF (“ANALOGUE Output Function”): the following is a code for the configuration of the ANALOGUE outputs.

AVF (“ANALOGUE Virtual Function”): the following is a code for the configuration of the virtual ANALOGUE inputs.

EVT (“Event”): the following is an event code

ST (“Status”): the following code shows the status of a dimension or a condition of the device or of one of its functions.

AL (“Event”): the following is an anomaly code.

1.6 Conventions

In this manual, the modifications, with respect to the previous version, are signalled by a vertical bar on the right of the paragraphs. The modifications on the fields of a table are highlighted with a grey background.

1.7 Software revisions

Several parts of this manual refer to the controller's software revisions. These revisions are marked with the assigned MECC ALTE code (shown on the rear panel of the controller). The format of the code is: EB0250256XXYY, where “XX” is the main version and “YY” is the minor version. Thus, the code EB02502560100 refers to the controller software release “1.00”. The software revision is also displayed on page “S.03” of the LCD display.

The software code available at the release date is:

- EB0250256xxyy **GC250**.

2 Views of the device

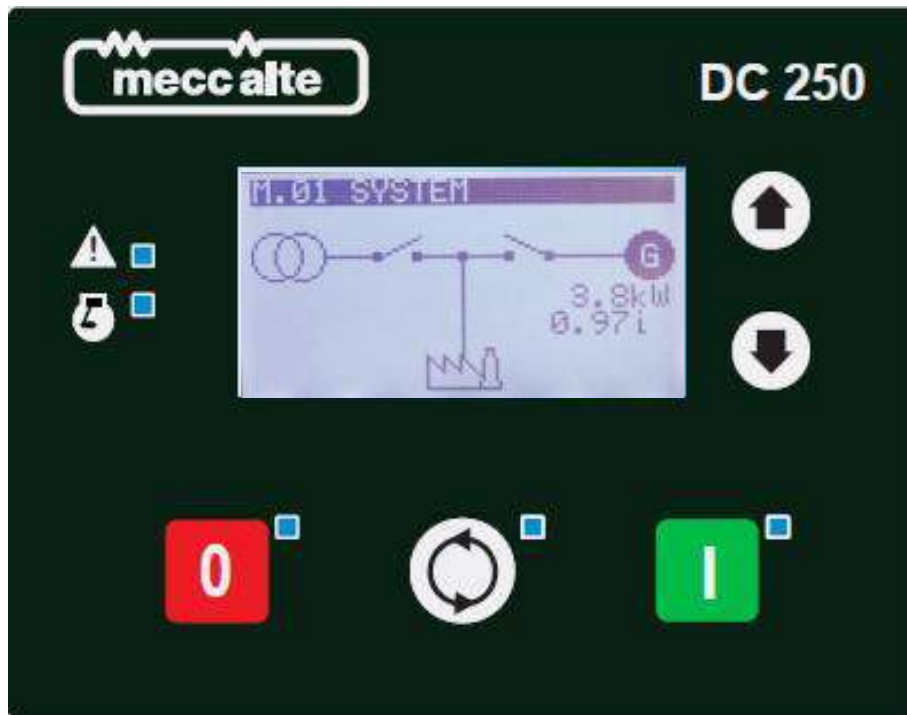

GC250 Front view



Back GC250

3 Technical features

Supply voltage Vbatt:	<p>7...32VDC with continuous operation, protections intervention at 60 VDC.</p> <p>Protection against the polarity inversion. Integrated self-restoring fuse.</p> <p>The operation is guaranteed during the engine start up to Vbatt=5VDC for an undefined time.</p> <p>The device identifies the plant operation at 12 or 24V to manage its alarms and for the selection of the excitation current of the generation of battery charge (signal D+) when powered up and whenever OFF/RESET mode is selected.</p>
Power consumption in stand-by	<p>No digital inputs active, engine instruments not connected:</p> <p>40mA @ Vbatt =13.5VDC display lamp on 26mA @ Vbatt =13.5VDC display lamp off 25mA @ Vbatt =27 VDC display lamp on 16mA @ Vbatt =27 VDC display lamp off</p> <p>No digital inputs active, engine instruments = 100ohm:</p> <p>61mA @ Vbatt =13.5VDC display lamp on 47mA @ Vbatt =13.5VDC display lamp off 35mA @ Vbatt =27 VDC display lamp on 28mA @ Vbatt =27 VDC display lamp off</p>
Power consumption in "Deep Stand-by Mode"	<p><3,4mA @ Vbatt =13.5VDC <4,3mA @ Vbatt =27 VDC</p> <p>(Available from HW E611215610001 and FW EB02502560104)</p>
Maximum power consumption in operating conditions (siren, LCD lamp, digital inputs active; communicating CANBUS; analogue inputs to GND; static outputs and +D not active)	<p>Max 230mA @ 7 VDC</p> <p>110mA @ 27 VDC 132mA @ 13.5 VDC</p>
Electric measurements for mains/generator set voltage and currents:	<p>ANALOGUE/digital conversion at 12bit; sampling frequency 10kHz. TRMS</p> <p>Measurement of the L-N phase voltages and of the L-L concatenated voltages; measurements of the neutral voltages referred to the power minus of the power supply of the device.</p> <p>Input impedance of the voltage measurements:</p> <p>> 280kohm L-N > 560kohm L-L >1600kohm L-GND >1450kohm N-GND</p> <p>Measurement of three currents through shunt with electric return and CT ratio in common.</p> <p>It is required the use of current transformers with a secondary current of 5A and minimum power of 1 VA (5VA suggested). It is mandatory to connect the return poles of the current transformers to the minus of the power supply of the device.</p> <p>Amperometric transformers must provide at least one REPEATED (DOUBLE) insulation for the use of the device in the Overvoltage Cat. III.</p> <p><u>Required connection of the return poles of the amperometric transformers (T.41) to the negative power supply of the device.</u></p>

Maximum mains/generator voltages allowed:	MAX 300Vac in CAT.III for measures L-N MAX 520Vac in CAT.III for measures L-L
Minimum mains/generator voltage measurable:	Matching with the minimum voltages required for the frequency measurement, see below.
Maximum currents allowed:	Continuous 5Aac. Transitory over current measure up to sine wave 20A (< 3s) with progressive loss of precision in measurement. Maximum transitory over current sine wave 50Aac (<1s).
Frequency measurements:	Rated frequency 50 or 60Hz, measurement from 3 to 99.9Hz Measurements obtained by the voltage of the L1 phases of mains/generator. Minimum sensibility for the minimum mains frequency: 24Vrms L-N @ 60 Hz Minimum sensibility for the minimum generator frequency: 29Vrms L-N @ 50Hz 32Vrms L-N @ 60Hz
Digital inputs	4 digital inputs with GND supply minus activation. The inversion of the activation logic from parameter is possible. When open, the voltage on the input terminals is 4.1V for the input T.16 and 4.6V for the other three inputs. Threshold of activation/deactivation 1.55VDC; typical current at close contact 4mA for T.16 and 4.6mA for the other three inputs. Maximum voltage applicable: 60VDC Minimum voltage applicable: -24VDC The input T.16 can be configured as analogue input for the measurement of the voltages (see below)
Statics Outputs	Four independent configurable outputs to battery plus, max 500 continuous mA each; internal limitation to approximately 4A max. on transients <150us and then thermal protection intervention. Protection against overload, short-circuit and voltage surge and integrated reverse polarity. Two independent outputs (T.05 and T.06) used in default for starter motor and fuel valve, max 10A resistive for 10s, 5A resistive continuous at 32VDC. Integrated thermal protection, over current, short circuit and inverse polarity. Use external opening overvoltage damping diodes, especially for inductive loads. For every static output, the outgoing current is supplied through the positive supply terminal of the T.02 (+BATT) device. The function of every single output is totally configurable from parameter.
Excitation output for recharge alternator +D	Maximum current switched automatically, depending on the supply voltage Vbatt: 200mA @ 13.5 VDC 100mA @ 27 VDC If it is not used for the excitation of the battery charger alternator, it is possible to configure the T.09 terminal as analogue input to acquire voltage measurements from 0 to 32V or as additional digital input with +Vbatt activation. The voltage measurement acquired is displayed in the page S.07 of the display.

Engine instruments analogue inputs	Three inputs for resistive sensors plus one input for measuring and compensation of the reference potential of their common minus. Resistance measuring range: range: 0...1kohm with error < 1% extended: 0 – 0...3kohm with error < 2% The three measurement inputs can also be used as digital inputs with GND activation, with status change voltage if 1.17VDC Voltage compensation range of the reference point, with Rsensors=100ohm: -2.7...+3.5VDC
Analogue inputs	The input T.16 can be configured from parameter to obtain voltage signals 0...10VDC referred to GND (T.01)
CANBUS Connection	USB 2.0 for non-permanent connection to PC (max 6m) only for the configuration of parameters with program SICES BoardPrg4. The device is directly supplied by PC and turns on in OFF/RESET mode when it is connected, with maximum consumption of 250mA from USB port.
CANBUS Connection	Canbus connection without galvanic isolation with protocol SAEJ1939 and MTU for the connection to ECU engine control. Fix internal termination of 120ohm
Display	Graphic transfective LCD, size 65x33mm, resolution 128x64 Self-regulating contrast with the temperature and with possibility of manual correction.
Operating conditions	From -30°C to +70°C, 95% not condensing humidity
Stock conditions	From -35°C to +80°C
Size	141(L)x113(H)x39(P)mm
Weight	191g the only device 250G with connectors and fixing
Dimensions of the mounting place	118x92mm
Protection degree	IP 65 external with mounted seal, IP20 internal

3.1 Measurement resolution

Mains/Bars and Genset voltages	1Vrms accuracy <1% F.S.
Current	Min. 0.1A (it depends on the CT ratio) accuracy <1% F.S.
Mains/Bars and Genset frequencies	0.1Hz ± 50ppm, 35ppm/C typical
Powers	Min. 0.1 kW/kVA/kvar (it depends on the CT ratio)
Power Factor	0.01
Energy	1 kWh/kvarh
Engine speed	1 rpm
Oil pressure	0.1bar (below 10bar)
Cooling liquid temperature	0.1°C
Fuel level	0.1%

4 Installation

4.1 Mounting

The device has to be mounted permanently on a panel. The rear panel of the device must be accessible only by keys or tools and only by authorized personnel for maintenance operations. It must be impossible to remove the controller without tools. The electric control panel has to guarantee an adequate protection against bad weather.

The mounting dimensions for the installation are 118x92mm. The mounting is carried out by four hooks with screws: once the device is positioned, insert the hooks in the holes on the sides and tighten the screws. Pay attention not to tighten excessively the screws in order not to damage the hook on the device.

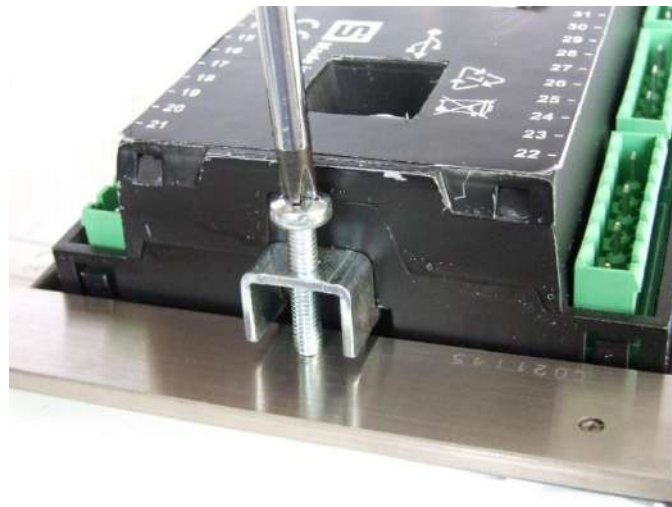

! WARNING! Operating temperature within the panel may vary between -30 °C and + 70 °C.
The outdoor operating temperature (ambient) may vary between -30 °C and + 60 °C.

4.2 Wiring

Due to the high voltages connected to the measurement circuits of the controller, all conductive parts of the electrical panel should be connected to the protective earthing through permanent connections.

The installation of an overcurrent protection device is required for each phase of the mains and generator voltage inputs. You can use 1A fuses.

The section of the protective earthing conductor should be at least equal to the section of cables used to wire mains or generator voltage to the control panel. In addition, it must comply with the limit value of the overcurrent protection used.

For CAT.III applications, the maximum phase-to-neutral voltage allowed is 300Vac, while the phase-to-phase voltage is 520Vac. The maximum voltage related to the protective earthing is 300 Vac.

The device can operate in CAT.III only if the supply minus terminal of the device and the neutral terminal of the generator are connected to the protective earth.

5 IN/OUT connections and configuration

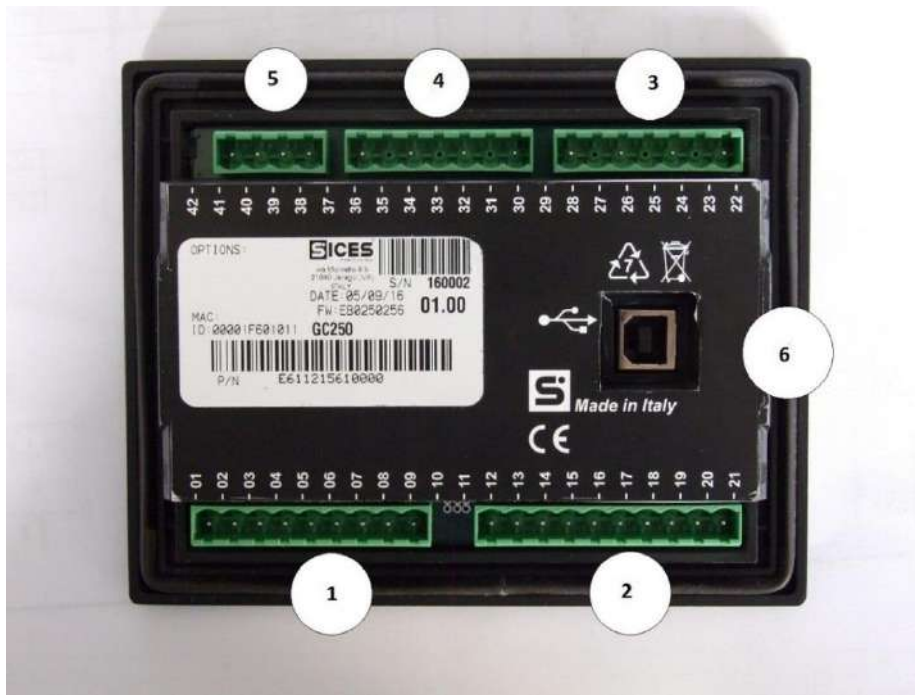

N.	NAME	TERMINAL	FUNCTION	DESCRIPTION	CONNECTOR
1	JA	T.01	GND	Device supply	9 poles x2.5mm 2 screw terminals
		T.02	+BATT		
		T.03	START	Configurable starter engine command	
		T.04	FUEL	Configurable fuel electro valve command	
		T.05	OUT 1	Configurable static outputs at +BATT	
		T.06	OUT 2		
		T.07	OUT 3		
		T.08	OUT 4		
T.09	+D, analogue input 0...32VDC	Output and +D signal detection /analogue input in configurable voltage			
2	JB	T.12	Analogue reference	Configurable resistor sensors/digital inputs	10 poles x2.5mm 2 screw terminals
		T.13	Fuel level		
		T.14	Oil pressure		
		T.15	Cooling liquid temperature		
		T.16	Digital input 1, analogue input 0...10V	Configurable digital inputs	
		T.17	Digital input 2		
		T.18	Digital input 3		
		T.19	Digital input 4		
		T.20	CAN_H	CANBUS connection and ECU engine	
		T.21	CAN_L		
3	JC	T.22	L3	Mains voltages	4 poles x2.5mm 2 screw terminals
		T.24	L2		
		T.26	L1		
		T.28	N		

4	JD	T.30	L3	Genset voltages	4 poles x2.5mm 2 screw terminals
		T.32	L2		
		T.34	L1		
		T.36	N		
5	JE	T.38	I1	Current measurement	4 poles x2.5mm 2 Screw terminal
		T.39	I2		
		T.40	I3		
		T.41	Common J1-2-3		
6	JX		USB		USB B

5.1 Correspondence input/output and their logic functions

In this document, we will always refer to the digital and analogue inputs and to the device outputs through the name of the respective terminal T.XX; by the way, to each terminal corresponds a logic function depending on its configuration and its usage. It can be useful in some cases, e.g. In the definition of logic functions AND and OR (see par. 5.6.4) or using the program BoardPrg4 to refer to the corresponding logic function.

The following chart indicates the correspondences between the terminals with its respective logic functions and the default configuration (N.U. =Not used, Available= usable according to the application requirements) and the primary function provided for the terminal. Some inputs can be configured and used both as digital inputs and as analogue inputs, therefore they are mentioned several times in the chart.

Terminal	Logic function	Default configuration	Main function
----------	----------------	-----------------------	---------------

DIGITAL OUTPUTS			
T.03	DO_CONTROLLER_T03 (START)	Starter motor	Starter motor
T.04	DO_CONTROLLER_T04 (FUEL)	Fuel solenoid valve	Fuel solenoid valve
T.05	DO_CONTROLLER_T05	Stop valve	Stop valve
T.06	DO_CONTROLLER_T06	External horn	External horn
T.07	DO_CONTROLLER_T07	MCB	MCB
T.08	DO_CONTROLLER_T08	GCB	GCB

DIGITAL INPUTS			
T.16	DI_CONTROLLER_T16	N.U.	Available
T.17	DI_CONTROLLER_T17	N.U.	Available
T.18	DI_CONTROLLER_T18	EMERGENCY STOP	EMERGENCY STOP
T.19	DI_CONTROLLER_T19	START INHIBITION	START INHIBITION
T.09	DI_CONTROLLER_T09	N.U.	Available
T.13	DI_CONTROLLER_T13	N.U.	Available
T.14	DI_CONTROLLER_T14	N.U.	Available
T.15	DI_CONTROLLER_T15	N.U.	Available

ANALOGUE INPUTS			
T.09	AI_CONTROLLER_T09 (DP)	N.U.	D+ Voltage measurement
T.13	AI_CONTROLLER_T13 (FL)	N.U.	Fuel level sensor
T.14	AI_CONTROLLER_T14 (OP)	N.U.	Oil pressure sensor
T.15	AI_CONTROLLER_T15 (CT)	N.U.	COOLING TEMPERATURE sensor
T.16	AI_CONTROLLER_T16	DIGITAL INPUT T.16	Available

5.2 Application type

The device can manage three types of application:

- **Auto Mains Failure:** it is the case of the emergency application, in which the electric mains status is monitored; the genset is usually started automatically in case of anomalies on the mains and it is stopped when anomalies stop.
- **Auto Start:** it is an application where the mains is not present; the generator is usually started manually or from remote to supply the loads.
- **DRIVE – engine only:** the controller does not manage a generator set, but only an engine (motor pump or other).

The selection is done through parameter P.0802

P.0802 = 0 for Auto Start applications.

P.0802 = 1 for Auto Mains Failure applications (default configuration)

P.0802 = 11 for DRIVE applications (engine only)

The digital outputs can be configured to activate/deactivate according to the type of application selected. AND/OR logics must be used, with the following states:

- ST.336: Auto Start application
- ST.337: Auto Mains Failure application
- ST.346: DRIVE application

According to the application type, the connection diagram changes, as indicated in the following paragraphs.

5.2.1 Principle connection diagram for Auto Mains Failure applications

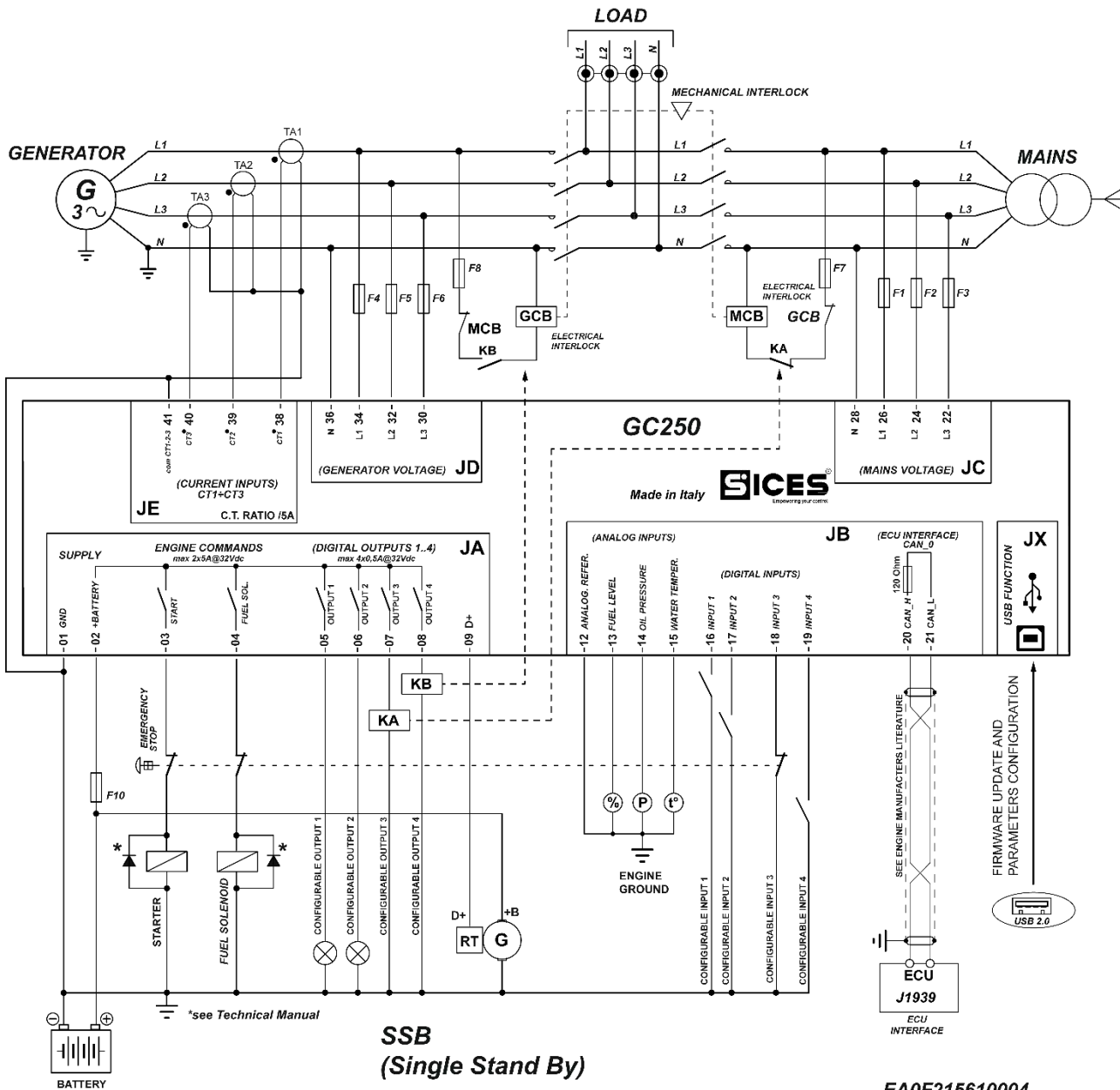

5.2.2 Principle connection diagram for Auto Start application

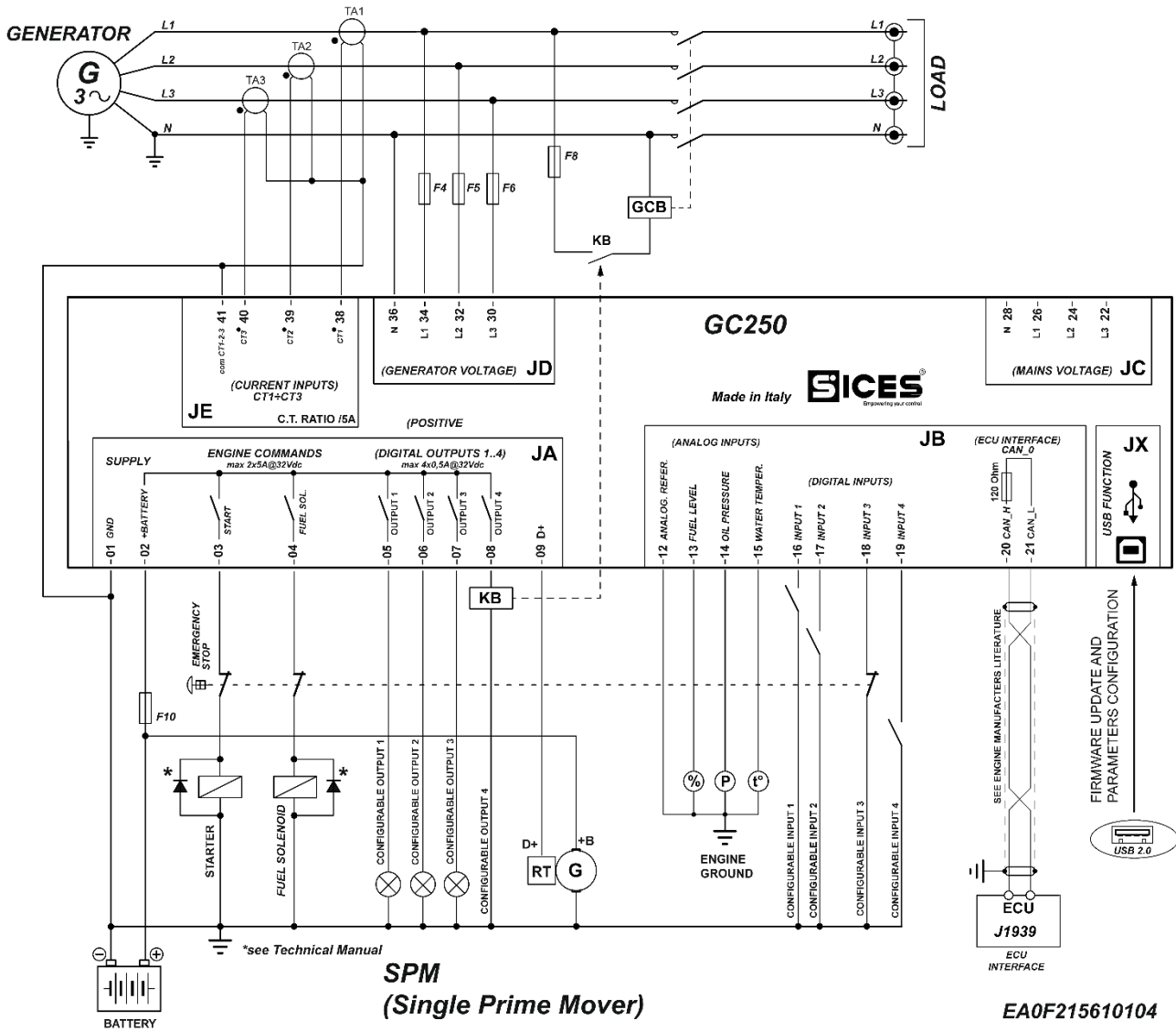

DIGITAL GENERATION

5.3 T.01 and T.02 Device supply

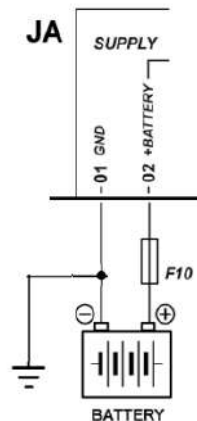

! ATTENTION! In order to respect the safety rules, an isolation of the supply from the public mains has to be guarantee in any case and must be lower than the one of a safety transformer compliant with norm IEC61558-2-6 or equivalent.

Connect a continuous source (usually the engine starting battery) to the terminal **T.01 GND** (minus) and to the terminal **T.02 +BATT** (positive).

The minus terminal **T.01-GND** is the reference and the common return of the digital inputs, outputs, current and voltage measurement. **It must be connected to the ground protection.** The systems that require insulation between the battery negative and the ground protection can be used but can generate operating problems and may require particular care, as the use of insulation current transformers for the voltage measurements of Mains and Genset.

Although the device is protected by a self-restoring internal fuse, the use of a fuse to protect the positive line **T.02 +BATT** of supply is still necessary (F10 in the diagram). **Through the positive input T.02 +BATT all the current supplied by the six static outputs T.03...08 and of signal +D (T.09) flows, and it is therefore necessary to pay attention to the fuse dimension.**

The device automatically acknowledges when it is powered if the genset battery nominal voltage is 12 or 24V for managing the related logics and alarms. Also, the acknowledgement is carried out every time you switch to the **OFF/RESET** mode.

! WARNING! when installing, connect the battery positive only after opening all fuses available in the panel.

5.4 Engine commands outputs T.03 and T.04

Basic diagram for switching off when de-energizing

The static outputs **T.03** and **T.04** are configured as per default for the connections of starter motor (**START**) and of fuel valve (**FUEL SOLENOID**). If not used to command the engine (e.g., With CAN-BUS engines), the two outputs are re-configurable from parameter to other purposes.

The status of the START and FUEL outputs is displayed on page S.06 (0= output inactive, 1= output active)

The outputs functions configured by default are the following:

Terminal	Function
T.03	DOF.1005 – “Engine start command”.
T.04	DOF.1003 – “Fuel temperature”

In detail:

5.4.1 T.03 START Command for the engine starter motor

Positive output at +BATT Integrated internal diode for damping opening over voltages. This terminal shows the battery voltage present on terminal **T.02**; although one is already present inside, with particularly inductive loads (remote control switches, electromagnets, etc.) **it is necessary to use a damper diode for opening over voltages.**



ATTENTION! for currents above the nominal value or for inductive loads with values higher than 500mH it's necessary to use an external relay.

The controller activates this command when motor start is required and deactivates it automatically within 200-300ms from the instant when it recognizes the motor started state.

If this command is not necessary (for example with CAN-BUS interface engines), the output can be configured for other purposes by means of the parameter P.3001, refer to par. 5.6.2 and [1].

5.4.2 T.04 FUEL SOLENOID Fuel solenoid command

Positive output at +BATT Integrated internal diode for damping opening over voltages. This terminal shows the battery voltage present on terminal **T.02**; although one is already present inside, with particularly inductive loads (remote control switches, electromagnets, etc.) **it is necessary to use a damper diode for opening over voltages.**



ATTENTION! for currents above the nominal value or for inductive loads with values higher than 500mH it's necessary to use an external relay.

The output is configured by default to control the fuel interception solenoid valve with de-energizing arrest systems (see below); if not used for this purpose (for example in the case of engines with CAN-BUS interface), it can be reconfigured to serve other purposes by means of the parameter P.3002, refer to par. 5.6.2 and [1].

There are two different ways to stop the engine:

Drop-down stop system

With this system (default configuration of the device) the engine is started by delivering power to the solenoid valve, which opens/closes the fuel flow and is turned off by cutting the power.

So, the controller activates the **T.03 FUEL SOLENOID** outlet prior to starting the engine (at least a delay of 200 ms is provided between the activation of this command and the activation of the command for the starter motor). It deactivates it when the motor must be turned off. If the engine is stopped by other means, it is possible to delay the deactivation of this command through parameter P.0234.

Pick-up stop system

This system is used when the engine requires an explicit command to stop. It is mainly used for safety reasons: in case of arrest during de-energizing, in fact, if you accidentally disconnect the wire connected to the **T.03** terminal, the engine stops. Instead, in case of shut-off while energizing, the engine does not stop until it receives the explicit arrest command.

By default, the positive auxiliary output **T.05** is configured for the command of arrest during energizing. You can configure any other output or even the same output **T.03 FUEL SOLENOID** (**while observing the warning below**) to give the shut-down command by setting the relevant parameters (refer to par. 5.6.1 and [1]).

 **WARNING:** The series connection of the emergency stop button to terminal **T.03** **DOES NOT WORK WITH SYSTEMS OF ARREST DURING ENERGIZING** because you would get the opposite effect, i.e. cutting the power to the stop valve, even if the controller activates the “**LOCKA048 Emergency stop**” and the output configured as stop command anyway.+ For these systems, in case you need to guarantee the operation of the mushroom push-button irrespective of the operation of the controller, it must have a double contact: one NC connected in series to the **T.03**, as shown before, to cut the power to the starter motor and one NO between battery plus and valve/stop command with no intermediate fuses which, when activated, delivers positive voltage to the stop valve by bypassing the controller command.

5.5 T.09 D+ Energizing and checking the operation of the recharge alternator

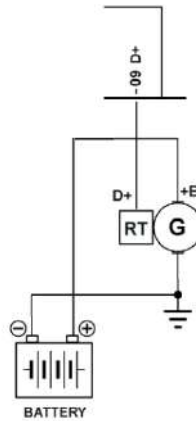

***i* INFORMATION!** To configure the T.09 for the +D connection at recharge alternator energizing you need to configure the parameter P.4041 with the value AIF.1300 – “Signal D+”. To use the T.09 for functions not correlated to D+ refer to par. 5.6.1, 5.5.2, 5.7.2 and correlated. The output is configured by default as AIF.0000 – “Unused”.

When the controller starts the engine, the T.09 terminal supplies the necessary power for energizing the battery recharge alternator.

With engine and alternator are idle, the D+ terminal of the alternator is practically a short circuit to the battery minus and the voltage at its ends is close to 0V. During and after engine starting, as well as under normal operating conditions, with the revolution of the recharge alternator, the +D voltage rises up to the value of the battery voltage. When the engine stops, or even if only the recharge alternator stops because of the breakage of the drive belt, the +D voltage returns to 0V. The same thing happens in case of malfunction of the alternator.

The power supplied with the alternator idle is internally limited and it is around 200mA for 12V systems and around 100mA for 24V systems; the selection of the current level is automatic.

The energizing command is activated on the engine start command.

During the engine start cycle, up to when the engine is no longer acknowledged as started with a method whatsoever (voltage, frequency, rpm, D+ voltage, oil pressure), the command is kept active for 30s continuously and then is deactivated/activated every 5s (5s ON followed by 5s OFF) until the starting sequence ends. When the engine is acknowledged as started, the command is kept active for 5 more seconds and then released.

Still through T.09, the controller measures the +D voltage of the recharge alternator, both during engine start and during its operation. It is displayed in the S.07 page, under item D+.

The voltage measure can be used for two purposes:

- Engine running/stop detection
- Usually, the recharge alternator is driven by the drive shaft through a drive belt. Normally, the drive belt also drives other mechanical components of the engine, for example the cooling fan of the radiator. If during engine operation the +D voltage of the recharge alternator drops below 0V or if it does not rise after start, once the P.0349 time is up, it is assumed that the belt is broken or at least that there is a malfunction and the controller activates the anomaly AL.005 (“A005 – Broken belt”) that can be configured with the parameter P.0357 (as warning, deactivation or lock) to protect the engine from the lack of operation of the mechanical parts driven by the belt.

Using parameters P.0230 and P.0231 it is possible to enable/disable the acknowledgement of engine started by D+ signal; by using the parameter P.0349 it is possible to disable the AL.005 anomaly (“A005 – Broken belt”) (see document [1]).

5.5.1 T.09 D+ Input used as analogue input

If the engine does not require the energizing connection, you can configure **T.09** as auxiliary powered ANALOGUE input, with measuring range 0-32VDC with respect to the power minus of the controller (GND), associating to it one of the functions available by means of the P.4001 parameter.

It can be used to acquire many measures, see par. 5.7.2 and the chart included.

5.5.2 T.09 D+ Input used as analogue input

It is possible to configure the input **T.09** as a further digital input, connected to a signal source between 0 and 32VDC. It is considered active when the voltage measured is higher than 4.0VDC; it is considered not active when the voltage measured is lower than 3.5VDC. Therefore, it cannot be activated like the other inputs, which is by connecting it to the ground. If it is configured as digital input, its status is displayed on page S.05 (0=input not active, 1=input active).

5.6 T.05.08 Static digital outputs and command loads switching

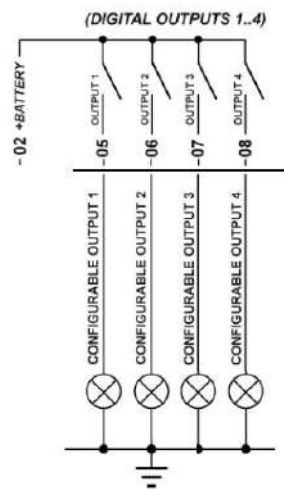

The device manages four digital outputs, entirely programmable. When activated, they bring themselves to the positive supply voltage on the **T.02** supply terminal. The rated capacity of each output is 500mA; the total power is, therefore, of 2A. **In full speed, do never overpass these values.**

The outputs are independent and protected individually from overloads, short circuits, polarity reversal and overheating. The overload protection cuts in to limit the current spikes to an instantaneous value of 4A, to allow the activation of loads that require a transient inrush current greater than the rated. If this condition persists, after 150us the thermal protection cuts in progressively, until the output is turned off.

With inductive loads (power relays, electromagnetic actuators), although some are already present inside, it is advisable to use diodes for damping opening over voltages.

All the current delivered by the outputs must be made available through the JE **T2-+BATT**; **make sure that any safety fuse on the supply plus has a capacity and response time suitable to power and protect both the outputs and the controller under any condition of use.**

The outputs functions configured by default are the following:

Terminal	Function
T.05	DOF.1006 – “Stop command when energized”.
T.06	DOF.3152 – “Outside beeper”

Terminal	Function
T.07	DOF.2004 - “MCB steady opening command”
T.08	DOF.2034 - “GCB steady closing command”.

5.6.1 Load switching commands Auto Mains Failure applications

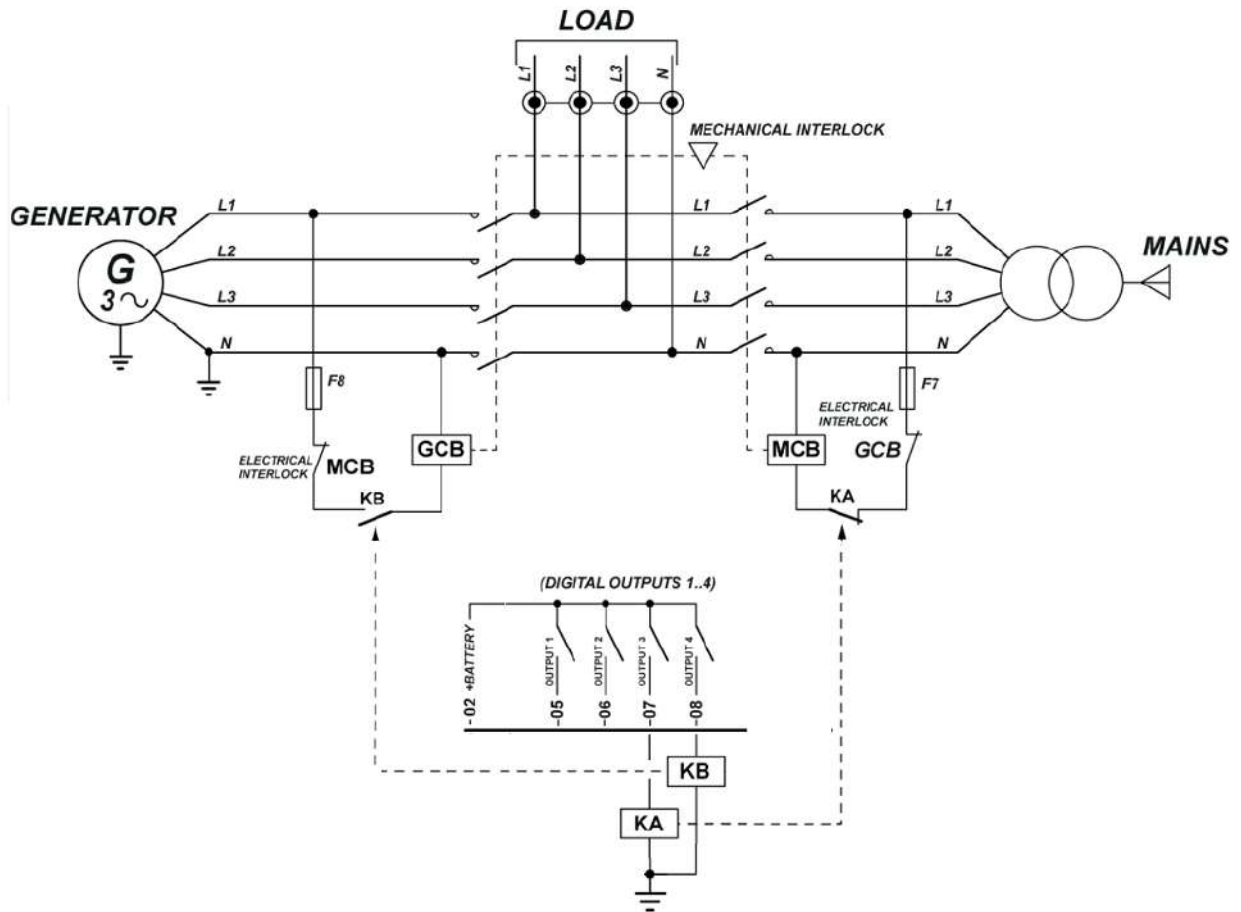

This is the default application type for the device (P.0802=1). It provides that the T.07 and T.08 outputs are dedicated to the command of the MCB and GCB contactors; To this purpose, it is by the way possible to configure any couple of static outputs, including outputs T.03 and T.04, unless they are not already used for the engine commands, matching them with the functions.

DOF.2004 - “MCB steady opening command”

DOF.2034 - “GCB steady closing command”.

The GCB command is used to connect the loads to the generator. The MCB command is used to connect the loads to the mains.

Two configurations are available to switch the loads between mains and generator:

- The wiring diagram above indicated provides the use of two contactors MCB and GCB **preferable mechanically and electrically interlocked** and operating in mains voltage, so to guarantee the automatic closure of MCB with mains live even in case of fault on the genset starting battery or on the device. This requires the use of two relay relays with KA and KB in battery voltage coils cabled as per the diagram. In case you use contactors directly operating in battery voltage coil, it is possible to command them directly from the static outputs of the device, inverting the polarity of the MCB output command (see par. 5.6.2) and observing the limits of current absorption indicated in par. 3

! WARNING! With circuit breakers operating in battery voltage and directly commanded by the controller outputs, if for any reason the device is no more supplied and/or in case of dysfunction, the loads are no more supplied by the mains.

Set parameter P.0220 to zero (the command can always be reversed immediately) and set within parameter P.0219 the pause interval that you want during change-over. The device uses logics that avoid the simultaneous closure of GCB and MCB, but by the way we strongly recommend you, to use the mechanic or electric interlocks.

- SWITCH (SIRCOVER): with only one command, the loads are changed over to the mains or to the generator. Configure parameter P.0220 with the time the SIRCOVER needs for the changeover: that way the controller avoids reversing the command before the changeover is completed, so to let SIRCOVER not to be subject to blocks). Instead, reset the P.0219 parameter, because the pause between mains and genset and vice-versa is ensured by the SIRCOVER.

For the changeover operation see par. 9.6

5.6.2 Load switching commands for Auto Start applications

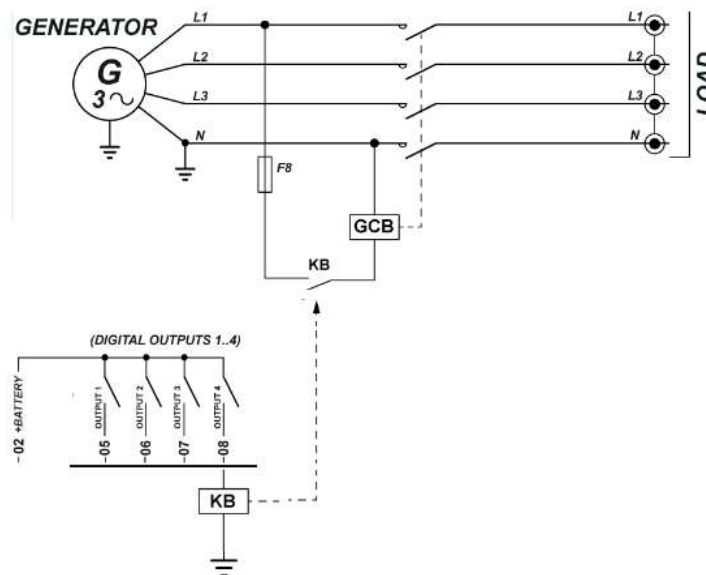

Auto Start configuration (parameter P.0802=0) provides only one circuit breaker, which insert/release the loads on the generator. The wiring diagram provides a circuit breaker **GCB** in mains voltage commanded by means of a relay; it is also possible to use a circuit breaker in battery voltage observing the limits of current of the output used.

In this type of application there is only one circuit contactor for manual gensets where the mains does not exist, commanded by only one output; in this way, with the controller not supplied, the loads are disconnected by the generator. Set to zero both parameter P.0220 and parameter P.0219.

The default configuration of the device provides a use of the output **T.08** that is specifically configured as default. It is by the way possible to use any digital output configured with the function.

DOF.2034 - "GCB steady closing command".

5.6.3 Digital outputs configuration

Each of the six digital outputs of the controller are singularly completely configurable.

The status of the digital outputs is displayed on page S.06 (0= output inactive, 1= output active).

By default, all outputs are activated when the related function requires it (for example the fuel pump output starts operating when the pump must be activated).

Using the BoardPrg4 it's possible to reverse the activation by simply ticking the "Reverse polarity" box on the top of the configuration page of every single output.

It is by the way possible to reverse the logic of the outputs directly operating on the controller (still singularly for each output) using parameter P.3000 for the outputs on the controller (6 bit in total)

- A zero-bit means that the output is normally on standby and starts operating when the related feature requires it.
- A one-bit means that the output is normally operating and goes on standby when the related function requires it.

The mapping of the outputs on the controller is:

Bit	Value	Output
0	1	T.03
1	2	T.04
2	4	T.05
3	8	T.06
4	16	T.07
5	32	T.08

Basically, if you want to reverse the logic of an output, it is necessary to add, in the relative parameter, the corresponding value: e.g. If you want to reverse outputs T.05 and T.06 on the controller, it is necessary to set P.3000 =12 (that is 4+8). By default, all bits are set to zero.

The digital outputs can be used directly as command for devices outside the controller, or for reporting certain operating conditions.

Functions configurable on the digital outputs

Code	Description.	Notes
DOF.0000	Not used.	
DOF.0103	AND/OR logics. X	The status of the output is the result of the combination of the AND/OR logics. See par. 5.6.4
DOF.1001	Glow plugs preheating.	Command for glow plugs preheating for Diesel engines; see par. 9.5.2
DOF.1003	Fuel valve.	Command for the fuel interception solenoid; see par. 9.5.2
DOF.1005	Engine start command.	Command for the starter motor; see par. 9.5.2
DOF.1006	Stop command.	Command for engine stop with arrest when energized; see par. 5.4.2 and par. 9.5.2
DOF.1032	Fuel pump.	Fuel pump activation command.
DOF.1034	Fuel pump solenoid valve.	Command to activate the fuel interception solenoid on the fuel pump line; see par. 11.1
DOF.1035	Inhibit DPF regeneration.	Command to inhibit the regeneration of the particulate filter; see par. 7.4.8.9.
DOF.1036	Force DPF regeneration.	Command to force the regeneration of the particulate filter; see par. 7.4.8.9.
DOF.1037	AdBlue pump	See 11.13
DOF.1038	Solenoid for AdBlue pump	See 11.13
DOF.2001	MCB under voltage coil.	See par. 9.6
DOF.2002	MCB opening coil.	See par. 9.6
DOF.2003	GCB opening coil.	See par. 9.6
DOF.2004	MCB stable opening command.	See par. 9.6
DOF.2031	GCB under voltage coil.	See par. 9.6
DOF.2032	GCB opening coil.	See par. 9.6
DOF.2033	Impulse closing command for GCB	See par. 9.6
DOF.2034	GCB stable closing command.	See par. 9.6
DOF.3001	Off/Reset	It activates when the controller is in OFF/RESET mode.
DOF.3002	MAN	It activates when the controller is in MANUAL mode.
DOF.3003	Auto	It activates when the controller is in AUTOMATIC mode.
DOF.3004	Test	It activates when the controller is in TEST mode.
DOF.3005	Remote start.	It activates when the controller is in REMOTE START mode.
DOF.3011	Controller not in OFF/RESET mode	It activates when the controller is in MAN or AUTO mode.
DOF.3012	One of the automatic modes.	It is activated when the controller is in one of the automatic operation modes that is AUTO, TEST or REMOTE START.
DOF.3032	Generator in tolerance	It is active when the mains parameters are within the "mains presence" window
DOF.3033	Mains in tolerance	It is active when the mains parameters are in the "mains live" window.
DOF.3061	Engine running.	It is active when the generator parameters are in the normal operation window
DOF.3121	Load thresholds	It is activated to report, depending on the configuration, a status of high load or low load. See par. 11.2
DOF.3151	Reset faults.	It is activated when the controller goes in RESET mode.
DOF.3152	Outside siren.	It is activated together with the internal siren.
DOF.3153	Lamp test	It is activated in OFF/RESET mode by pressing the STOP key: it can be used to turn on possible external led to the controller, and have one only procedure to test the warning lights
DOF.4001	Warnings	It is activated in presence of warnings
DOF.4003	Deactivations	It is activated in presence of deactivations
DOF.4004	Alarms.	It is activated in presence of alarms

DOF.4005	Alarms, deactivations and unloads.	It is activated in the presence of alarms, deactivations and unloads.
DOF.4031	Generator faults.	<p>It is activated in the presence of faults of the generator, i.e.:</p> <ul style="list-style-type: none"> ▪ 001: Minimum generator voltage. ▪ 002: Maximum generator voltage. ▪ 003: Minimum generator frequency. ▪ 004: Maximum generator frequency. ▪ 006: Maximum current. ▪ 008: Standard operation conditions not met. ▪ 016: Short circuit. ▪ 052: Voltage unbalance. ▪ 053: Current unbalance. ▪ 055: Wrong phase sequence. ▪ 056: Low generator voltage. ▪ 058: Low generator frequency. ▪ 059: High generator voltage. ▪ 060: High generator frequency.
DOF.4032	Engine faults.	<p>It is activated in the presence of faults of the engine, i.e.:</p> <ul style="list-style-type: none"> ▪ 005: Belt break (generator battery-charger failure) ▪ 021: Engine not stopped. ▪ 022: Engine not started. ▪ 031: High coolant temperature (from contact). ▪ 032: High coolant temperature (from analogue sensor) ▪ 033: Maximum coolant temperature (from contact). ▪ 034: Maximum coolant temperature (from analogue sensor) ▪ 035: High oil temperature (from analogue sensor). ▪ 037: Start battery low voltage. ▪ 038: Start battery high voltage. ▪ 039: Service required. ▪ 041: Minimum oil pressure (from contact). ▪ 042: Minimum oil pressure (from analogue sensor). ▪ 043: Low oil pressure (from contact). ▪ 044: Low oil pressure (from analogue sensor) ▪ 049: High power. ▪ 054: High oil temperature (from analogue sensor) ▪ 062: Fault in connection to the CAN bus. ▪ 065: Low coolant temperature (from analogue sensor) ▪ 098: Communication with engine interrupted. ▪ 105: Belt from Can-Bus is broken. ▪ 132: High temperature of the coolant from the Can-Bus. ▪ 134: Maximum temperature of the coolant from the Can-Bus. ▪ 135: Minimum level of the coolant from Can-Bus.

		<ul style="list-style-type: none"> ▪ 136: Low level of the coolant from Can-Bus. ▪ 137: Low battery voltage from Can-Bus. ▪ 142: Minimum oil pressure from Can-Bus. ▪ 144: Low oil pressure from Can-Bus. ▪ 158: High oil temperature from Can-Bus. ▪ 159: Maximum oil temperature from Can-Bus. ▪ 198: Cumulative of warnings from Can-Bus. ▪ 199: Cumulative of the alarms (locks) from Can-Bus
DOF.4034	Fuel faults.	<p>It is activated in case of faults in the fuel level, i.e.:</p> <ul style="list-style-type: none"> ▪ 025: Minimum fuel level (from contact). ▪ 026: Minimum fuel level (from analogue sensor) ▪ 027: Low fuel level (from contact). ▪ 028: Low fuel level (from analogue sensor) ▪ 029: High fuel level (from contact). ▪ 030: High fuel level (from analogue sensor) ▪ 160: Water in fuel from Can-Bus.
DOF.4035	Breakers faults.	<p>It is activated in case of faults of the GCB and MCB breakers, i.e.:</p> <ul style="list-style-type: none"> ▪ 013: Mains circuit breaker not closed ▪ 014: Genset circuit breaker not closed ▪ 023: Mains circuit breaker not open ▪ 024: Genset circuit breaker not open

5.6.4 AND/OR logics

The AND/OR logics are, basically, a list of boolean conditions (true/false, on/off, 1/0), which can be configured by the operator (programming), which the controller evaluates and the result of which can be assigned to a digital output (see par. 5.6.1). For using the AND/OR logics with a digital output, use the DOF.0103 function.

***i* INFORMATION!** the configuration of the AND/OR logics cannot be carried out directly from the controller display, but it has to be carried out by PC with the BoardPrg4 software.

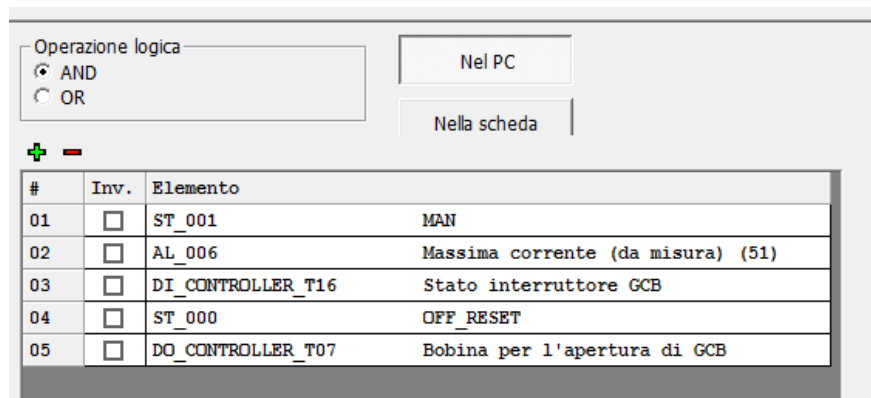

Operazione logica

AND

OR

Nel PC

Nella scheda

#	Inv.	Elemento	
01	<input type="checkbox"/>	ST_001	MAN
02	<input type="checkbox"/>	AL_006	Massima corrente (da misura) (51)
03	<input type="checkbox"/>	DI_CONTROLLER_T16	Stato interruttore GCB
04	<input type="checkbox"/>	ST_000	OFF_RESET
05	<input type="checkbox"/>	DO_CONTROLLER_T07	Bobina per l'apertura di GCB

It is necessary to decide whether the list of conditions has to be evaluated as AND (they have to be all verified) or as OR (it is enough that at least one condition is verified). **It is not possible**

to have mixed logics AND/OR (it is possible using the virtual digital inputs, see afterwards).

You can add up to 30 conditions. Each condition can be denied individually: in the previous figure, for instance, the controller will check that the digital input 3 and the digital output 6 are both **inactive**. The following conditions can be added:

- DI_XXX: logic statuses of all digital inputs (physical).
- DO_XXX: logic statuses of all digital outputs.
- AL_XXX: presence of warning/alarms.
- ST_XXX: internal statuses of the controller.
- AT_XXX: statuses concerning the thresholds on ANALOGUE measures (see par. 5.7.2) In fact, every digital input can have an AND/OR logic associated, which determines its status.

The following table shows the list of the internal states available for the AND/OR logics.

Status	Description
ST_000	OFF_RESET
ST_001	MAN
ST_002	AUTO
ST_003	TEST
ST_004	REMOTE START
ST_006	Acknowledgment of anomalies in progress
ST_007	Reset of anomalies in progress
ST_008	Warnings cumulative
ST_010	Deactivations cumulative
ST_011	Alarms cumulative
ST_012	Unacknowledged warnings total
ST_014	Unacknowledged deactivations cumulative
ST_015	Unacknowledged blocks total
ST_016	Presence of mains voltage/frequency
ST_017	Mains out of tolerance or off
ST_018	Delay for mains in tolerance
ST_019	Mains in tolerance
ST_020	Delay for mains out of tolerance or off
ST_024	Generator voltage/frequency present
ST_025	Generator out of tolerance or absent
ST_026	Delay for generator within tolerance.
ST_027	Generator in tolerance
ST_028	Delay for generator out of tolerance or absent
ST_032	Engine started
ST_033	Oil protections enabled
ST_035	Engine sequence: standby
ST_036	Engine sequence: starting
ST_038	Engine sequence: delay before power delivery
ST_039	Engine sequence: ready to deliver
ST_040	Engine sequence: cooling
ST_041	Engine sequence: arrest
ST_064	GCB status
ST_065	MCB status
ST_068	Impulse closing command for GCB
ST_069	Impulse closing command for MCB
ST_070	GCB under voltage coil command
ST_071	Impulse open command for GCB
ST_072	Impulse closing command for GCB
ST_073	MCB under voltage coil command

ST_074	Impulse open command for MCB
ST_075	Impulse closing command for MCB
ST_080	Contact start inhibition
ST_081	Clock/Calendar start inhibition
ST_088	Inhibition of the GCB closing from contact
ST_090	Inhibition of the GCB closing from serial port
ST_096	Ready to supply
ST_104	Supply
ST_112	Synchronization every second
ST_113	Synchronization every minute
ST_114	Synchronization every hour
ST_128	Glow plugs preheating command
ST_130	Fuel electro valve command
ST_132	Start engine command
ST_133	Excitation stop command
ST_137	Inhibit DPF regeneration
ST_138	Force DPF regeneration
ST_256	CAN 0 BUS-OFF
ST_257	CAN 0 ERR-PASSIVE
ST_258	CAN 0 ERR-ACTIVE
ST_259	No communication on CAN 0
ST_304	STOP button
ST_305	AUTO button
ST_306	START button
ST_307	UP button
ST_308	DOWN button
ST_320	Status 01 from engine management by file
ST_321	Status 02 from engine management by file
ST_322	Status 03 from engine management by file
ST_323	Status 04 from engine management by file
ST_324	Status 05 from engine management by file
ST_325	Status 06 from engine management by file
ST_326	Status 07 from engine management by file
ST_327	Status 08 from engine management by file
ST_328	Status 09 from engine management by file
ST_329	Status 10 from engine management by file
ST_330	Status 11 from engine management by file
ST_331	Status 12 from engine management by file
ST_332	Status 13 from engine management by file
ST_333	Status 14 from engine management by file
ST_334	Status 15 from engine management by file
ST_335	Status 16 from engine management by file
ST_336	Application type: Auto Start
ST_337	Application type: Auto Mains Failure
ST_346	Application type: DRIVE
ST_998	Always active
ST_999	Always not active

5.7 Analogue inputs

The device is equipped with three inputs designed for the connection to resistive-type sensors **T.13**, **T.14**, **T.15**, and their common **T.12**.

In addition, two voltage analogue measure inputs are present, referring to GND:

T.09 in alternative to the use as D+ signal, it can be used as input for voltage analogue signals 0...32VDC; also see par. 5.5.1.

T.16 in alternative to the use as digital input, it can be used as input for voltage analogue signals 0...10VDC; also see par. 5.8.2

5.7.1 T.13, T.14, T.15 - Resistive analogue inputs

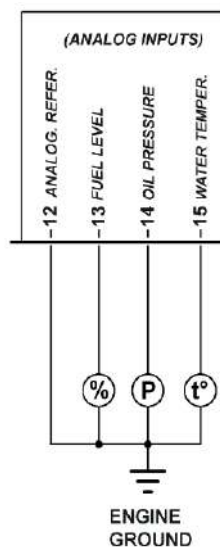

The device is equipped with three inputs designed for the connection to resistive-type sensors **T.13**, **T.14**, **T.15**. There is also an input for the measurement of their common ground potential **T.12**.

The four values of the voltage measured on terminals, and their related value of sensors resistance, are displayed on page S.07.

The inputs have a useful field of resistive measure between 0 and 1kohm with voltage to the terminal **T.12** compared to GND equal to zero. It is by the way possible to measure values of resistance up to 3kohm (always with voltage **T.12**=0V), but with a higher error of measure (see the characteristics of care at par. 3)

The three inputs are between themselves electrically identical. Each input can be singularly configured for the measure of the resistive signals; by default, the analogue measures are not enabled.

⚠ ATTENTION! we recommend in any case to observe the functions provided for each single resistive input, according to the connection diagram above, that is with:

T.13 Fuel level input (FL Fuel Level)

T.14 oil pressure input (OP Oil Pressure).

T.15 Coolant Temperature (CT Coolant Temperature)

So, to observe the denominations already provided in BoardPrg4 and the reference diagrams.

5.7.1.1 Input T.12 ANALOGUE reference (Analogue Reference)

It is not a real measure input: it is used only together with the three inputs for resistive sensors. Its purpose is to compensate for the lack of equipotential between electric earthing of the device (terminal **T.01 GND**) and of the electric panel and electric earthing of the gen-set, usually generated by the voltage drop on the connection cables; particularly, this happens when the connections between electric panel and engine are long and when there is a power flow in the battery minus and earthing connections, for example due to the presence of the battery recharge device inside the electric panel.

The input measures the potential of the common ground point (negative) of the resistive sensors, which for the sensors mounted on the engine is represented directly by the engine itself or the chassis of the gen-set.

 **ATTENTION!** T.12 must be connected with a predisposition of ground or with a bolt on the engine. Do not connect T.12 to GND in the electric control panel or directly to terminal T.01.

Note: this connection should be made using a dedicated wire having the shortest possible length. Avoid making the wire lies near high power and high voltage cable.

If the minus of one or several sensors is isolated from the engine or the gen-set chassis, for example in the case of floats for fuel level measurement mounted on the plastic tanks or electrically separated from the gen-set, you need to connect the **T.12** to the return of the sensor and also to the negative electric mass of the engine or to the negative limit of the starting battery.

The system is able to efficiently compensate for both positive and negative potentials, ranging between -2.7VDC and +3.5VDC, with sensors resistance values of 100 ohm. The range of compensation increases for lower resistor values and decreases for higher values of resistor, being optimized for the resistor values of the sensors in normal operating conditions of the system.

The measure of the voltage with respect to the GND terminal is displayed on page S.07, under item T.12; the measuring range of the system, and therefore the value indicated, can be higher than the one useful for compensation, mentioned above.

5.7.1.2 Input T.13, T.14, T.15 used as digital inputs

It is possible to singularly configure the three resistive analogue inputs as further digital inputs, configuring them with function “**AIF.0100**”, see par. 5.7.2.

In order to activate the input, you need to connect it to the ground, and let it float to deactivate it. So, these will be displayed in the configuration menu of the digital inputs and will be manageable exactly as the other inputs; see par. 5.8. If one or more inputs are configured as digital inputs, their statuses are displayed on page S.05 (0=input not active, 1=input active). The inputs that are not configured as digital will be displayed with a hyphen.

5.7.2 Configuration and functions of analogue inputs

The analogue inputs can be used to acquire different predefined measures, or to acquire generic sensors (therefore tailor made). Some measures can be only acquired by some inputs (see the following chart).

As for the measures concerning the engine (pressure, temperature) with engine having digital control unit, normally those data are directly acquired directly via CAN-BUS; sometimes it may be necessary the use and the configuration of the resistive level sensor.

For all these measures you can choose standard sensors with the most common resistance values directly from the configuration parameters of each individual sensor by using the controller or, through the BoardPrg4 program, you can define known generic curves at least two couples of resistance points/value of the size to be measured, see par. 5.7.3.

At the same time, it is possible to match a curve voltage/value of the measure for the two analogue inputs in voltage **T.16** and **T.09**.

To every analogue input is associated a set of eight parameters to define the type of function, an alternative denomination and a series of thresholds and general configurations usable for different functions; below are shown as examples those relative to the input **T.13**. For the parameters of the other inputs, refer to documents [1] or to the configuration page I/O of BoardPrg4.

***i* INFORMATION!** On BoardPrg4 the parameters are all displayed only when the input is really configured as analogue input and not, for example, as digital.

We have:

- One parameter, which configures its function (P.4009 for input **T.13**).
- One parameter which configures any message to be shown on the display (P.4010 for input **T.13**).
- Two thresholds consisting of three parameters each:
 - One parameter, which configures the threshold value (P.4011 and P.4014 for input **T.13**).
 - A parameter which configures the delay to manage the “out of threshold” (P.4011 and P.4015 for input **T.13**).
 - One parameter, which configures the checking options and the actions in case of “out of threshold” (P.4013 and P.4016 for input **T.13**).

***i* INFORMATION!** the thresholds defined here do not depend on any threshold set within the menus “Protections”; for example, for the coolant temperature sensor you can set a high temperature threshold through the parameter P.0337 to stop the engine and a pair of independent temperature thresholds through the parameters described above, used to create other alarms, different signals or logics.

The parameter containing the message for a certain ANALOGUE input (in the example above, what is written in the P.4010 parameter) is displayed and used by the controller every time the thresholds are used to activate warnings and/or alarms (see below)

It is also used for the AIF.2001 function of the ANALOGUE inputs. In this case the measure acquired will be displayed on page E.31, preceded by the message configured. **NOTE: you can also use the AIF.2051 function instead of the previous three. in this case, the measure acquired will not be displayed on display; however, you can still use it with the thresholds to manage digital outputs and activate warnings/locks.**

The two thresholds are completely independent on each other. The third parameter of each threshold is a “bit” parameter that allows you to associate to each threshold the following options:

- Bit 0 If this bit is “OFF”, the controller checks if the measure is higher than the threshold. If this bit is “ON”, the controller checks if the measure is lower than the threshold.
- Bit 1. If this bit is “OFF”, the controller sets to OFF the internal status related to this ANALOGUE measure if the measure is “out of threshold”. If this bit is “ON”, the controller sets to ON the internal status related to this ANALOGUE measure if the measure is “out of threshold”.

- Bit 4. If this bit is “ON”, the controller issues a warning if the measure is “out of threshold”.
- Bit 6. If this bit is “ON”, the controller issues a deactivation command if the measure is “out of threshold”.
- Bit 7. If this bit is “ON”, the controller issues a lock command if the measure is “out of threshold”.
- Bit 8. If this bit is “ON”, the controller activates a fault only if the engine is activated.
- Bit 9. If this is a bit “ON”, the controller activates a fault only if the time of covering the alarm of low oil pressure has passed.
- Bit 10. If this bit is “ON”, the controller checks that the GCB is closed, to activate possible warnings/locks configured with the preceding bits.
- Bit 11. If this bit is “ON”, the controller activates a fault only if the fuel valve is activated.
- Bit 13. If this bit is “ON”, to activate any warning/lock configured with the preceding bits, the controller checks the status of any digital input configured with the function “2705 - Disable the protections on the ANALOGUE measures”. The warnings/locks will be activated if no digital input is configured as such, or if they are all OFF.
- Bit 14. If this bit is “ON”, the fault entails the arrest of the fuel pump

You can set any combination of these bit.

The following table shows the list of functions that can be associated to the ANALOGUE inputs:

Function	Denomination	Thresholds	T.16	T.13 T.14 T.15	T.09
AIF.0000	Not used			X	X
AIF.0100	Used as digital input			X	X
AIF.1000	Oil pressure (VDO)	X		X	
AIF.1001	Oil pressure (general)	X	X	X	X
AIF.1100	Oil temperature (VDO)	X		X	
AIF.1101	Oil temperature (general)	X	X	X	X
AIF.1110	Coolant temperature (VDO)	X		X	
AIF.1111	Coolant temperature (general)	X	X	X	X
AIF.1200	Oil level (VDO)	X		X	
AIF.1201	Oil level (general)	X	X	X	X
AIF.1210	Coolant level (VDO)	X		X	
AIF.1211	Coolant level (general)	X	X	X	X
AIF.1220	Fuel level (VDO)	X		X	
AIF.1221	Fuel level (general)	X	X	X	X
AIF.1300	D+ Signal	X			X
AIF.1601	Air temperature in the intake pipe	X	X	X	X
AIF.1603	Exhaust gas temperature (left bank)	X	X	X	X
AIF.1605	Exhaust gas temperature (right bank)	X	X	X	X
AIF.1641	Turbo pressure	X	X	X	X
AIF.2001	Generic sensor (page 1)	X	X	X	X
AIF.2051	Generic sensor	X	X	X	X

All odd functions AIF.XXXX require the use of program BoardPrg4 for the definition or the upload of the sensor characteristic curve (see par. 5.7.3). In fact, every digital input can have an AND/OR logic associated, which determines its status.

Functions AIF.1000, AIF.1100, AIF.1110, AIF.1200, AIF.1201, AIF.1210, AIF.1220 use pre-set conversion curves suitable for the VDO most common sensors instead.

Temperature sensor VDO (AIF.1100, AIF.1110)	
0 °C	1800 Ohm
50 °C	195 Ohm
100 °C	38 Ohm
150 °C	10 Ohm

Pressure sensor VDO (AIF.1000)	
0 bar	10 Ohm
10 bar	180 Ohm

VDO Level Sensors (AIF.1200, AIF.1210, AIF.1220)	
0 %	180 Ohm
100 %	10 Ohm

5.7.3 Conversion curves

The conversion curves are a tool which allow you to convert a numerical value into another numerical value. They can be used to convert the value acquired by an analogue input of voltage or resistance to the real measure unit of the sensor.

***i* INFORMATION!** the conversion curves cannot be configured directly from the panel of the controller board, but through a PC equipped with the BoardPrg4 software.

Once created, the curves can be saved on file to be reused, including on other controllers.

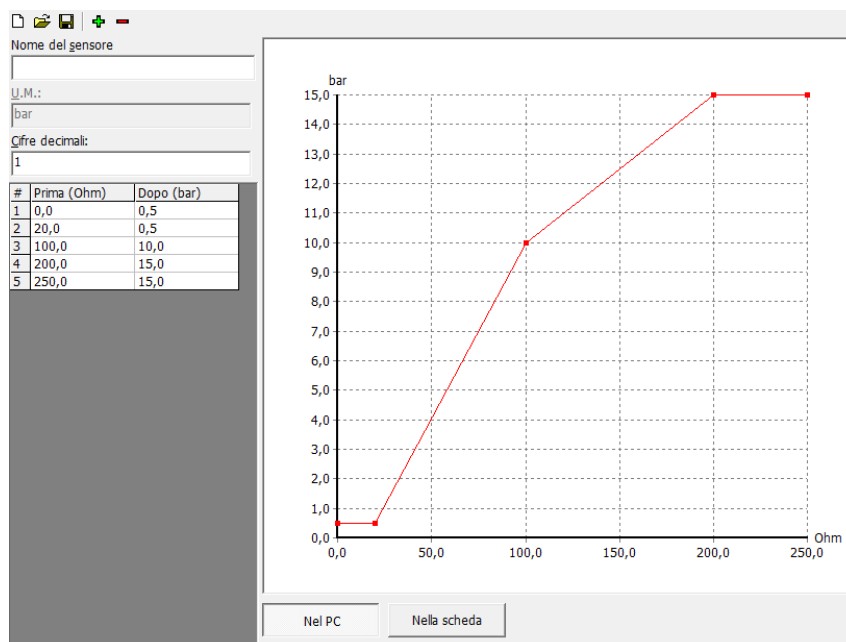

The previous figure shows a hypothetical conversion/resistance/pressure curve associated to an analogue resistive input. You can add up to 32 points in the graph, thus creating also non-linear curves. See in the example that the curve configured has two horizontal segments at the beginning and at the end, obtained by entering two equal values in the “After” column, corresponding to two different values in the “before” column. This is not obligatory, but it allows you to set a saturation limit on one end or on both ends of the curve. In fact, the controller board extends to infinity the first and last segments of the curve. Being horizontal, whatever value the measure “to convert” assumes, you will obtain the same value of the “converted” measure.

The BoardPrg4 software allows you (by means of the first buttons on top left) to save the curve on file to be able to use it again in other applications. So, you can create an archive of the conversions associated to the sensors used.

In case the curve is associated to a physical ANALOGUE input configured with the function AIF.2001 (“Generic sensor”), the measure converted will be displayed on page E.31: in this case you can also specify (through the conversion curve) how many decimal digits will the value displayed have, as well as its unit of measurement).

5.8 Digital inputs

The device has 4 specific digital inputs **T.16**, **T.17**, **T.18** and **T.19**.

Beside them, if not used as measure inputs, it is also possible to use analogue inputs as digital **T.13**, **T.14** e **T.15** (see par.0) and, with different modes, also the terminal **T.09** (D+ signal, see par.5.5.2). All digital inputs or inputs used as digital, are configurable.

In addition, there are 16 “virtual” inputs available, which are not really present on the controller or on the expansions, but they are obtained as a result of the logical combination of physical or virtual inputs, outputs, alarms or logical states by means of proper programming via BoardPrg4. The virtual inputs can be configured as feature and can be used the same way as the physical inputs.

5.8.1 T.16...19 DIGITAL INPUTS

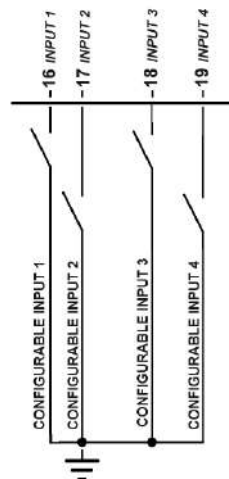

The device has 4 digital inputs, which can be activated by connecting them to GND. When left floating, the inputs go to around 4.5VDC (around 4.15VDC for input T.16). Avoid situations where intermediate or undefined voltage levels can occur.

If you don't use the same signal shared among different devices beside GC250, it is recommendable the use of series diodes at the inputs as per the following figure:

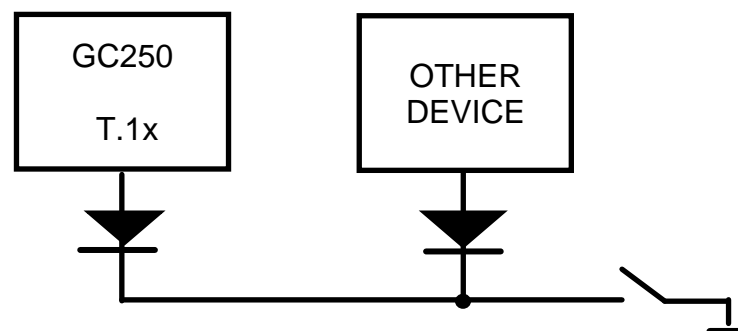

By default, the functions of the inputs are the following:

Terminal	Function
T.16	DIF.0000 – “Not used”
T.17	DIF.0000 – “Not used”
T.18	DIF.4201 – “Emergency stop”
T.19	DIF.2501 – “Genset start inhibition”

⚠ WARNING! input T.18 is by default configured to manage the emergency stop command signal; for safety reasons, this function uses an inverted logic, that is, during the normal operation the terminal T.18 must remain connected with GND through a NC contact in the emergency button; when the contact opens, the relative alarm is generated (see wiring diagram par. 0)

5.8.2 T.16 D+ Input used as analogue input

Input **T.16** can be configured to acquire analogue signals of 0...10VDC voltage by selecting in parameter P.4033 one of the functions typical of the analogue tools. By default, the parameter is set with function **AIF.0100 - “Used as digital input”**. See par. 5.7.2

5.8.3 Virtual digital inputs

In addition to the 4 digital physical inputs the controller also operates 16 virtual digital inputs (from revision 01.07). The same are operated by the controller just as if they were physical inputs (with no limitation), but the status of the virtual inputs is not acquired from the hardware, but it is determined through the software. In fact, every digital input can have an AND/OR logic associated, which determines its status.

A practical example of use. Suppose you want to activate a warning if the mains voltage exceeds the tolerance thresholds. Let us use the virtual digital input #1 (as example).

- Using the BoardPrg4 software we associate an AND/OR logic configured as AND to the #1 virtual digital input, with the following list of conditions:
 - ST.064 (“Status of the GCB”)
 - ST.017 (“Mains out of tolerance or absent”).
- The virtual digital input will therefore be active when the GCB is closed, and the mains is out of tolerance.
- Let us set the DIF.4001 function (“Generic warning”) within the P.2151 parameter.
- Let us set the desired delay (for example 0.5 s) within the P.2152 parameter.

5.8.4 Digital inputs configuration

By default, all the digital inputs are considered “active” when the related terminal is connected to the supply minus of the controller; they are considered “not active” when the related terminal is not connected to anything. **The logic status of the input can be inverted with respect of the physical status by selecting the box “Reverse polarity” in the input configuration page on BoardPrg4.** The box is only visible if the function selected is other than DIF.0000 – “Not used”.

It is also possible to invert the logic status (single based for each input), operating directly on the controller using parameters P.2000 for inputs **T.16...T.19** and P.2100 (for the analogue inputs when used as digital).

These parameters have a bit for each output:

- A bit set to zero means that the related input is “active” when it is connected to the negative supply of the controller.

- A bit set to one means that the related input is considered “active” when it is not connected to anything (it will become “not active” if it is disconnected to the supply negative terminal of the controller).

By default, all bits are set to zero.

To each input two parameters are associated:

- A parameter that configures the function of it (P.2001 for the input **T.16**, the consecutive parameters for the other inputs).
- A parameter that configures a possible delay of the function activation (P.2002 for the input **T.16**, the consecutive parameters for the other inputs).

See documents [1] for the parameters list.

The parameter that configures the delay for an input is used by the controller only for some input functions. The following chart highlights when it is used:

***i* INFORMATION!** in BoardPrg4, the box for the delay is always displayed, even if is not used by the controller.

The input functions that start with 3xxx are related to the functioning status; those that start with 4xxx activate alarms (alarms, deactivation, warning).

Function of the xx input	Denomination	Delay	Description
DIF.0000	Not used.		Input not used.
DIF.1001	GCB closing command		It only acts in MAN and TEST modes, used to control the manual closing of the GCB circuit breaker. If there is no input configured with the function DIF.1002, this input works in reality as toggle: it commands the closure of the breaker when the same is open and commands the opening when the same is closed.
DIF.1002	GCB opening command.		It only acts in MAN and TEST modes, used to control the manual opening of the GCB circuit breaker.
DIF.1031	MCB closing command.		Only acts in MAN and in TEST, used to control the manual closure of the MCB breaker. If there is no input configured with the function DIF.1032, this input works in reality as toggle: it commands the closure of the breaker when the same is open and commands the opening when the same is closed.
DIF.1032	MCB opening command.		Only acts in MAN and in TEST, used to control the manual opening of the MCB breaker.
DIF.2001	Alarm reset command.		When the input becomes active, the controller executes a reset of all anomalies. That is equivalent to change the controller mode to OFF/RESET and back again to the desired mode.
DIF.2031	TEST mode command.		When the input is “active”, the mode of the controller switches from AUTO to TEST (the input does nothing if the controller is not in AUTO or if the automatic intervention of the genset is required). When it becomes inactive, the status changes back to AUTO.
DIF.2032	REMOTE START command.	Yes	If the input is “active”, the controller operating mode changes from AUTO to REMOTE START (the input does nothing if the controller is in OFF/RESET or MAN mode). When it becomes inactive, the status changes back to AUTO.

DIF.2033	Manual start request.		When the input “activates” (only in MAN mode), the controller tries to start (only once) in the same way of an automatic start, that is commanding the motor up to the start success or failure.
DIF.2034	Manual stop request.		When the input activates (in MAN mode), the controller commands the stop of the engine. It equals to pressing the STOP button.
DIF.2041	Request of load taken in manual		When the input activates (only in manual mode) the opening of MCB and the closing of GCB are required, and vice versa when it deactivates.
DIF.2071	Inhibit DPF regeneration.		When the input is "active", the controller "prevents" the regeneration of the particulate filter to the engine ECU. See par. 7.4.8.9.
DIF.2072	Force DPF regeneration.		When the input is "active", the controller requires the regeneration of the particulate filter to the engine ECU. See par. 7.4.8.9.
DIF.2151	Select configuration 1.		When the input <u>becomes</u> “active”, parameters of alternative configuration set 1 are copied in the working configuration.
DIF.2152	Select configuration 2.		When the input <u>becomes</u> “active”, parameters of alternative configuration set 2 are copied in the working configuration.
DIF.2271	Remote OFF.		When this input is active, the operating mode of the controller is forced to OFF-RESET, and it is not possible to use the pushbuttons on the front panel to change it. <i>i</i> INFORMATION! when this deactivates, if no inputs are configured with the functions DIF.2272 and DIF.2273, the operating mode is forced to the one set before the input activation.
DIF.2272	MAN by remote control.		When this input is active, the operating mode of the controller is forced into MAN, and you cannot use the buttons on the panel to change it.
DIF.2273	AUTO by remote control.		When this input is active, the operating mode of the controller is forced into AUTO, and you cannot use the buttons on the panel to change it.
DIF.2501	Genset start inhibition		When the input is “active”, the automatic start of the engine is inhibited. For this function, the parameters “Delay” is not used, whatever its value. The “REMOTE START” mode is not influenced by this function
DIF.2502	Inhibition to the taking of load		Automatically, when this input is “active”, the opening of the GCB circuit breaker is forced (and the closing of MCB too).
DIF.2703	It enables the load thresholds.		If the input is <u>not active</u> , the management of the load thresholds (described in par. 11.2) is disabled
DIF.3001	GCB status.	Yes	It is used to detect the actual status of the KM/MCB circuit breaker. In case of discordance between status and command, a signalling will outline it.
DIF.3002	MCB status.	Yes	An input configured in this way is used to activate early warnings in the event of a discrepancy between the controls to the switch given by the board and the status of the same switch. Warning can be also issued in this case or, even, depending on the configuration, the genset can be started in case of MCB closure failure. It is also used to detect the status of the circuit breaker when it is commanded by external devices.
DIF.3101	External mains sensor.		When the input is “active” the mains is considered to be “in tolerance”.
DIF.3301	Fuel level for pump start.		If the input is “active” the fuel pump is started (see par. 11.1).

DIF.3302	Fuel level for pump stop.		If the input is “active” the fuel pump is stopped (see par. 11.1)
DIF.3311	Level for starting AdBlue pump		See 11.13
DIF.3312	Level for stopping AdBlue pump		See 11.13
DIF.4001	General warning.	Yes	If the input is “active”, a warning is issued: the message shown is the one set by means the related “text” parameter.
DIF.4003	General deactivation.	Yes	If the input is “active”, a deactivation command is issued: the message shown is the one set by means of the related parameters.
DIF.4004	General alarm.	Yes	If the input is “active”, an interlock is issued: the message shown is the one set by means of the related “text” parameter.
DIF.4011	Warning (after oil delay).	Yes	If the input is “active”, an alarm (block) is issued if the time set by means P.0216 is elapsed from the engine running detection. The message shown is the one set by means the related “text” parameter.
DIF.4013	De-activation (after oil delay).	Yes	When the input is “active”, if the time set by means of the P.0216 parameter from engine start has elapsed, a deactivation command is issued: the message shown is the one set by means of the related parameters.
DIF.4014	Alarm (after oil delay).	Yes	If the input is “active”, an alarm (block) is issued if the time set by means P.0216 is elapsed from the engine running detection. The message shown is the one set by means of the related “text” parameter.
DIF.4021	Warning (if GCB closed).	Yes	When the input is “active”, if a GBC command is active, a warning is activated.
DIF.4023	Deactivation (if GCB is closed).	Yes	When the input is “active”, if a GBC command is active, a deactivation is commanded.
DIF.4024	Interlock (if GCB is closed).	Yes	When the input is “active”, if a GBC command is active, an alarm is activated.
DIF.4031	Warning (if FUEL is enabled).	Yes	When the input is active, if the fuel solenoid valve control (JH_03) is active, a warning is activated.
DIF.4033	Deactivation (if FUEL is enabled).	Yes	When the input is active, if the fuel solenoid valve control is active, a deactivation is commanded.
DIF.4034	Interlock (if FUEL is enabled).	Yes	When the input is active, if the fuel solenoid valve control (JH_03) is active, an interlock is activated.
DIF.4051	Warning (the fuel pump is turned off)	Yes	If the input is “active”, a warning is issued: the message shown is the one set by means the related “text” parameter. The controller blocks the fuel pump as long as this input is “active”
DIF.4201	Emergency stop	Yes	
DIF.4211	Minimum fuel level	Yes	If the input is “active”, an interlock with a fixed description (language-dependant) is activated. This function can be also used for the “Fuel pump management” (see par. 11.1) In fact, every digital input can have an AND/OR logic associated, which determines its status (see par.).
DIF.4212	Low fuel level	Yes	If the input is “active”, a warning with a fixed description (language-dependant) is activated. This function can be also used for the “Fuel pump management” (see par. 11.1) In fact, every digital input can have an AND/OR logic associated, which determines its status (see par.).

DIF.4213	High fuel level	Yes	If the input is “active”, a warning with a fixed description (language-dependant) is activated. This function can be also used for the “Fuel pump management” (see par. 11.1). In fact, every digital input can have an AND/OR logic associated, which determines its status (see par.).
DIF.4221	Minimum oil pressure	Yes	When the input is “active”, if the time set by means of the P.0216 parameter from engine start has elapsed, a fixed description (language-dependant) interlock is activated.
DIF.4222	Low oil pressure	Yes	When the input is “active”, if the time set by means of the P.0216 parameter from engine start has elapsed, a fixed description (language-dependant) warning is activated.
DIF.4231	High coolant temperature	Yes	When the input is “active”, if the time set by means of the P.0216 parameter from engine start has elapsed, a fixed description (language-dependant) warning is activated.
DIF.4232	Maximum coolant temperature	Yes	When the input is “active”, if the time set by means of the P.0216 parameter from engine start has elapsed, a fixed description (language-dependant) warning is activated.

5.9 T.22...T.28 Connection to the mains

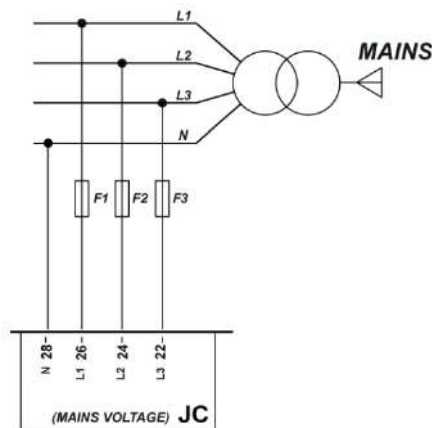

The connection with the public electric mains happens by means of terminals **T.22**, **T.24**, **T.26**, **T.28**, using protection fuses (suggested 1A)

Depending on the type of application:

- **Auto Start:** the mains is not connected to the device; the terminals remain unused.
- **Auto Mains Failure:** the mains is connected with the device. In this way, the controller can acknowledge faults on the mains and start the genset.

Three-phase connection:

- Connect the neutral (if any) (N) to the terminal **T.28**
- Connect phase L1 (or R) to the terminal **T.26**
- Connect phase L2 (or S) to the terminal **T.24**
- Connect phase L3 (or T) to the terminal **T.22**

Single-phase connection:

- Connect the neutral (if any) (N) to the terminal **T.28**

- Connect phase L to the terminal **T.26**

Parameters P.0119 allows to select the three-phase/single-phase mode.

For CAT.III use, the maximum working voltage is 300Vac (phase-neutral) and 520Vac (phase to phase). Maximum voltage to ground is 300 Vac.

The controller uses phase L1 (terminal **T.26**) to measure the frequency of the generator.

5.9.1 Measurement of the mains neutral

The device, in three-phase connection, can function both with the neutral connection and without it; selection is performed through the P.0129 parameter.

If the system is configured with the neutral connection, the neutral voltage is measured in relation with GND.

The values of the V1-N, V2-N and V3-N phase voltages and the VN voltage of the neutral in relation to GND for the mains are displayed on page M.03.

If the device is configured not to measure the neutral voltage, then page M.03 will not be displayed.

5.10 T.30...T.36 Connection to generator

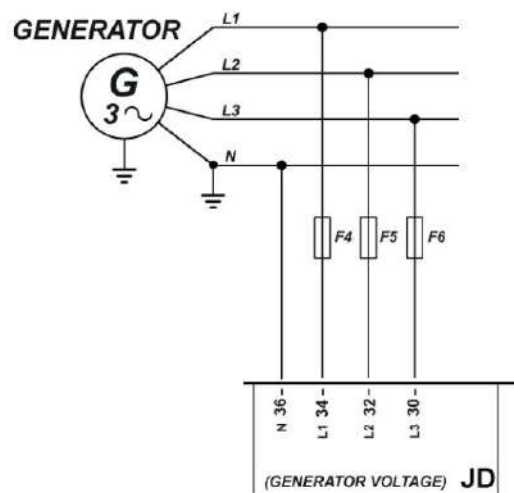

The connection with the generator happens by means of terminals **T.30, T.32, T.34, T.36**, using protection fuses (suggested 1A)

Three-phase connection:

- Connect the neutral (if any) (N) to the terminal **T.36**
- Connect phase L1 (or R) to the terminal **T.34**
- Connect phase L2 (or S) to the terminal **T.32**
- Connect phase L3 (or T) to the terminal **T.30**

Single-phase connection:

- Connect the neutral (if any) (N) to the terminal **T.36**
- Connect phase L to the terminal **T.34**

Parameters P.0101 allows to select the three-phase/single-phase mode.

For CAT.III use, the maximum working voltage is 300Vac (phase-neutral) and 520Vac (phase to phase). Maximum voltage to ground is 300 Vac.

The controller board uses phase L1 (terminal **T.34**) to measure the frequency of the generator.

5.10.1 Measurement of the generator neutral

The device, in three-phase connection, can function both with the neutral connection and without it; selection is performed through the P.0128 parameter.

If the system is configured with the neutral connection, the neutral voltage is measured in relation with GND.

The values of the V1-N, V2-N and V3-N phase voltages and the VN voltage of the neutral in relation to GND for the mains are displayed on page M.05.

If the device is configured not to measure the neutral voltage, then page M.05 will not be displayed.

5.11 T.28...T.40 Current transformer connection.

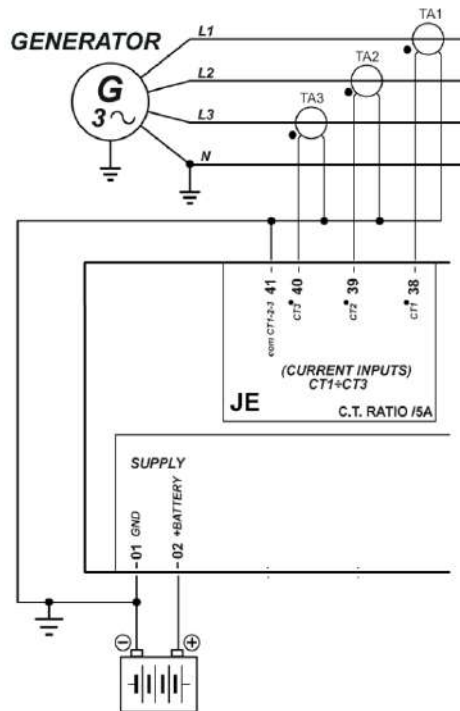

The current measurement shall be made exclusively by means of current transformers (CTs) with secondary by 5Aac and which guarantee suitable isolation.

⚠ WARNING! Do not connect to terminals T.38...T.41 for measuring conductors' currents with mains voltage.

Any current measurement needs a power of about 1VA; however, CTs of 5VA are recommended, to compensate for leaks along the connection cables.

The maximum current that the device can measure directly is of 5.3Ac, beyond which the measurement circuit gets saturated. The controller board is still able to measure (but with gradually decreasing precision) down to about 20 Ac solely for transient situations and for a time lower than 3s, such as measuring over currents or short circuit currents on the system, using an algorithm to compensate for the saturation of the measurement circuits.

The TA measuring the three currents have a sole terminal **T.41** for the return current.

The measurement is carried out by shunt.

! WARNING! IMPORTANT: terminal T.41 with all CT's back, **MUST** be connected to T.01 GND supply negative of the device.

If the CTs have to be connected to other devices in addition to the controller, it must be the last in the series.

- Connect to terminal **T.38** a terminal of the CT connected on phase L1.
- Connect to terminal **T.39** a terminal of the CT connected on phase L2.
- Connect to terminal **T.40** a terminal of the CT connected on phase L3.
- Connect to terminal **T.41** the returns of all three CTs.

For single phase connection, terminals **T.39** and **T.40** should not be connected.

The P.0107 sets the current values of the CTs primary.

6 Communication resources

6.1 USB Connection



GC250 has a USB port with B-type connector for a temporary connection with a PC for the parameter's configuration or for the download of history logs.

The USB protocol specifications do not allow it to be used permanently in the industrial sector due to limited length of the cable and to the relatively elevated sensitivity to electrical disturbances including on the PC side. For this reason, **the USB connection cable must only be inserted when it is necessary to operate on the device and it must be removed from the connector when the operation is finished.**

i INFORMATION! The device is directly supplied by the PC through USB cable, and it turns on as soon as it is connected, so to let the parameters programming be easily possible and without external supply. Make sure that the PC can provide at least 300mA through the USB port used.

i INFORMATION! With supply by USB, the light if the LCD display can be reduced compared to the normal operation; this is normal, and it is not to be considered a device fault.

! WARNING! When the device is supplied by the sole USB port, it is not to be considered operative and must not be used to command the genset.

The PC to be connected must have the **CDC_Sices_Win.inf** driver installed, which is supplied by SICES; for driver installation refer to document [7].

After installing the driver, the PC will acknowledge the controller as a new serial port, to be used just as if it were an RS232 serial.

The configuration parameter is P.0479: order of Modbus registers per USB serial port

The USB connection to a PC is used for three purposes:

- Parameter's programming
- Reading/download history logs
- Enabling the device firmware

The parameters programming is carried out through program SICES BoardPrg4, which, beyond this, allows the resetting of the counters, the synchronisation of the internal clock of the device with the one of the PC and the configuration saving on file. For the use of the program, refer to the document [2].

The download of the history logs can be realised by means of special software tools.

Loading/replacing the firmware of the device is a specific operation of MECC ALTE; in addition to the operating FW to be loaded, it requires a particular procedure and specific programs and normally this procedure must not be carried out by the person who performs the installation, except in specific situations previously agreed on with MECC ALTE.

6.2 RS485 (optional).

Optionally, it is possible to request an additional RS485 serial port, not supplied as standard.

This port is galvanically isolated, and allows remote monitoring/control of the GC250, with the distances guaranteed by the RS485 standard.

This serial port can be configured with the parameters present in menu 5.1 (available from firmware version 1.09):

- P.0452: it configures the Modbus address of GC250 on the RS485 port.
- P.0453: it configures the communication speed (baud rate).
- P.0454: it configures the communication characteristics (number of data bits, number of stop bits, parity).
- P.0470: it establishes how 32-bit measurements are divided into adjacent Modbus registers:
 - LSWF: the lower index register contains the lower 16 bits of the measurement.
 - MSWF: the lower index register contains the highest 16 bits of the measurement.

The status of the serial port is visible on page S.04 of the GC250 display.

6.3 CAN-BUS connections

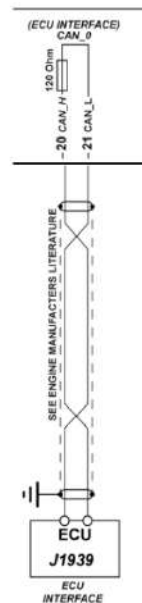

Using engine equipped with ECU (Electronic Control Unit) and CAN-BUS interface, most of the previous detailed connections are no more required. With only one connection (CAN-BUS to be more precise) the controller is able to start or stop the engine, as well as to control its speed, to make several measurements (such as running speed, coolant temperature and oil pressure) and to display the diagnose codes activated by the engine itself.

For the connections described below it is necessary to use a special type cable for CAN-BUS connections (see documents [5] [6]). For the CAN-BUS connections see documents [3] [5] e [6].

For features and operation details, as well as for the configuration of the CAN-BUS communication parameters, see documents [4], [5] e [6].

The CAN-BUS interface of the GC250 is not galvanically isolated.

Connections:

- Connect terminal **T.20** to terminal CAN_H of the engine's control unit.
- Connect terminal **T.21** to terminal CAN_L of the engine's control unit.
- Connect the shielding mesh of the shielded cable to the protective earth or to signal on both sides make sure that interior, panel and the engine frame are kept at the same potential).

The CAN-BUS connection needs a 120-ohm termination resistor on both ends of the cable. Inside the GC250 device, the ending is fix.

Normally, the control units of the engine have the termination resistor built-in; if not, connect the resistor directly on the CAN_H and CAN_L terminals of the control unit.

***i* INFORMATION! NOTE: the termination must always be enabled, unless the connection proceeds to other devices and the Controller is not one of the two ends.**

Use the parameters from menu 7 (in particular parameters P.0700 and P.0703) to indicate to the controller board the type of engine with which it must interact and the functions that must be managed.

7 Command and indications

7.1 Front panel GC250

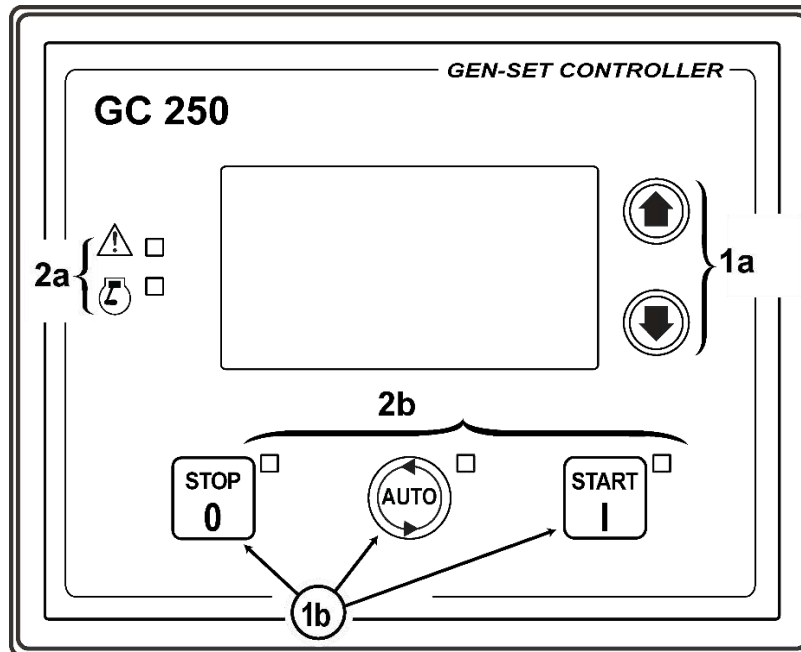

Fig. 1 – GC250 Front Panel

KEY





- 1 - Push-button
- 2 - Indicators

The controls consist of 5 buttons (1a, 1b).

The front panel also has 5 luminous indicators (2a, 2b).





7.2 Pushbuttons

By default, by pressing any button, the device emits a short sound of confirmation. It is possible to deactivate the sound, by turning to 0 bit 7 of parameter P.0495.

Push-button		Function
	UP	Select the view of the next page or of the next browsing menu; if kept pressed for at least one second, you go up to the upper-level menu.
	DOWN	Select the view of the next page or of the last browsing menu; if kept pressed for at least one second, you go down to the lower-level menu.
	STOP / OFF-RESET	<p>In AUTO, MAN, TEST or REMOTE START is used to command the engine stop and force the mode OFF-RESET.</p> <p>In AUTO, TEST or REMOTE START, the button can be configured in two ways (bit 0 OF P.0495):</p> <ul style="list-style-type: none"> - Stop of the engine with the activation of a lockout. - No function. - The pushing of a button is irrelevant. <p>Pressed with the board in OFF/RESET mode it runs the LAMP TEST on all the luminous indicators.</p> <p>In OFF/RESET mode pressed for at least one second together with the button AUTO allows to access the programming menu.</p> <p>When the genset control module is activated, keeping it pressed at the same time as the START button allows access to the special functions.</p>
	AUTO	By pressing the button for around half a second, the controller provides for the automatic management of the generator, which will be started when the plant conditions require it.
	START / MANUALE	<p>By pressing the button for around half a second, the controller provides for the manual management of the generator. If the "Protected Start" function (bit 2 of P.495) is disabled, the engine start is immediately commanded according to the two following ways; if enabled, by pressing one time, you select only the operation mode MAN and it is necessary to press another time to start the engine.</p> <p>The button can also be configured to command the engine start according to two ways (bit 1 of P.0495):</p> <ul style="list-style-type: none"> • Fully manual (the starter motor is engaged all the time the button is pressed or until the engine running is detected). • Fully automatic (simply press and release the "START" button to activate an automatic start sequence. If the start is not successful, start failure anomalies will not be reported. The "START" button must be pressed and released again to perform a new start attempt. <p>When the controller is turned on, keeping it pressed at the same time as the STOP button, it allows access to the special functions.</p>

7.3 Indicators

LED OFF	LED steady ON	LED flashing
<input type="checkbox"/>	<input checked="" type="checkbox"/>	<input checked="" type="checkbox"/>

	Signalling		Function
		<input checked="" type="checkbox"/>	Indicates that the operation mode is OFF/RESET
		<input checked="" type="checkbox"/>	Indicates that you are accessing the PROGRAMMING menu
		<input type="checkbox"/>	The Gen-set control module is in another operating mode.
	AUTO	<input checked="" type="checkbox"/>	Indicates that the operation mode is AUTOMATIC
		<input checked="" type="checkbox"/>	Flashing at 50% indicates that the operating mode is TEST Flashing at 90% indicates that the operating mode is REMOTE START .
		<input type="checkbox"/>	The Gen-set control module is in another operating mode.
	MANUAL	<input checked="" type="checkbox"/>	Indicates that the operation mode is MANUAL
		<input checked="" type="checkbox"/>	Indicates that the operation mode is MANUAL and that the protected start mode is active.
		<input type="checkbox"/>	The Gen-set control module is in another operating mode.
	ALARM	<input checked="" type="checkbox"/>	Indicates the presence of at least one lockout, one deactivation or power-off
		<input checked="" type="checkbox"/>	There is at least one active warning.
		<input type="checkbox"/>	No anomalies.
	ENGINE RUNNING	<input checked="" type="checkbox"/>	Indicates engine running
		<input type="checkbox"/>	Indicates engine idle

7.4 Multifunctional display

7.4.1 LCD lighting

The back light lamp is managed by the Gen-set control module, which switches off the back light after a programmable time (P.0492) if no buttons are pressed in the meantime. To turn it on again it is enough to push any key. This function can be disabled by setting parameter P.492 to 0.

During engine starting phase, the lamp is automatically turned-off to reduce the power consumption of the controller board, in order to ensure greater autonomy for the controller itself in the event of critical conditions of the starter battery. Using the P.0493 parameter, you can force the lamp to stay always on when is engine is started.

7.4.2 Contrast adjustment

Depending on the environmental temperature conditions, the contrast may require adjustment in order to view the display correctly.





Press in sequence button **AUTO**  + **DOWN**  to decrease the contrast (lighten), press button **AUTO**  + **UP**  to increase it (darken).

7.4.3 Mode navigation

The display has different visualization modes composed by different pages.



Fig. 2 - Mode navigation menu

Mode	Icon	Description	Page identifier
PROGRAMMING		Programming	P.XX
STATUS		Status information	S.XX
MEASURES		Electrical measurements	M.XX
ENGINE		Engine measurements	E.XX
HISTORY		History logs	H.XX

Normally, the mode navigation is carried out by keeping pressed for at least one second the

buttons **UP**  and **DOWN** 

By pressing the arrow for at least one second **UP**  the navigation mode menu opens (a window with the icons that identify the available modes). With the same arrows it is possible to move the highlighted reverse icon to one direction or to the other.

By keeping pressed for at least one second the arrow **DOWN**  it is selected and displayed the desired mode.

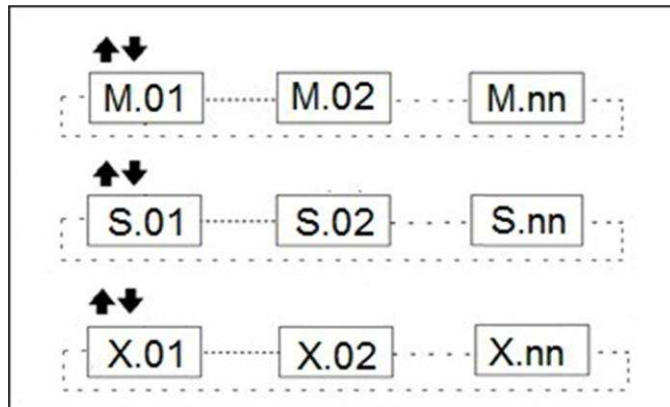



Fig. 3 - Mode navigation

To view the pages inside the mode you can use the buttons **UP**  and **DOWN**  **Ref. 1c.**

7.4.4 Structure of display areas

KEY:
1 - Status bar
2 - Data area

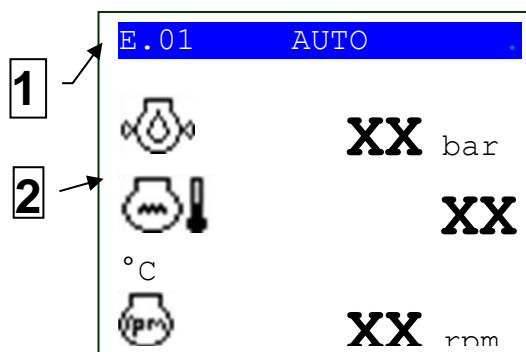

Fig. 4 - Display areas

7.4.5 Top status bar

The top status bar contains information on navigation, times and/or some status information.

KEY:
1a - View Mode identifier
1b - Page identifier
2 – Controller operation mode

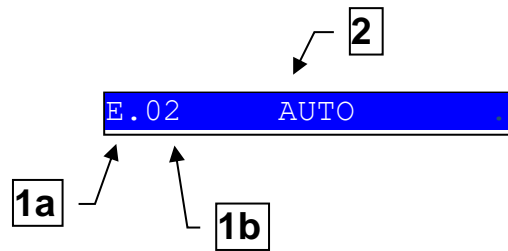

Fig. 5 - Top status bar

The current mode is shown in the relevant field of the top status bar (2). The indicated statuses can be **OFF, MAN, AUTO, TEST, REMOTE START**.
The view of the operation mode doesn't change when the pages change.























The view mode identifier (1a), and the page identifier (1b) identify and refer to the page so there is no chance of error.





7.4.6 Status information (S.XX)

In this mode, the information on the system status is supplied. You can scroll through the various pages using ▲ e ▼ buttons.

7.4.6.1 S.01 STATUS

Page S.01 displays information on the system status. It contains:

- The controller operation mode:
 -  : Controller in OFF/RESET mode
 -  : Controller in Manual mode.
 -  : Controller in automatic mode.
 -  : Controller in remote start mode.
 -  : Controller in TEST mode
- The status of the engine sequence:
 -  : engine idle (stand-by).
 -  : glow plug preheating
 -  : engine start.
 -  : delay of starting attempts.
 -  : delay of first supply.
 -  : engine running.
 -  : engine cooling.
 -  : stopping cycle
- The status of the electrical mains (absent, low, high etc.)
 -  (Flashing) Lack of Mains voltage.
 -  (Flashing) Mains voltage present, but “out of tolerance” (low).
 -  (Flashing) Mains voltage present, but “out of tolerance” (high).
 -  : Mains voltage present and “within tolerance”.
- The status of the generator voltage (absent, low, high etc.)
 -  : Lack of voltage on the generator.
 -  : Generator voltage present, but “out of tolerance” (low).
 -  : Generator voltage present, but “out of tolerance” (high).
 -  : Generator voltage present and “within tolerance”.
- The status of the changeover:
 -  : MCB circuit breaker closed.

-  : GCB circuit breaker closed.
-  : both circuit breakers open.
- The possible presence of inhibitions to generator start.
 -  : start allowed.
 -  : start inhibited.

Some information is shown alongside an elapsing time; for example, during engine cooling down, the residual time is shown.

7.4.6.2 S.02 ANOMALIES

The page S.02 is automatically displayed in case a new anomaly arises. For every anomaly, it is shown:

- A letter that identifies the type of it:
 - “A”: alarm (block)
 - “D”: deactivation.
 - “W”: warning.
- A three-digit numeric code that uniquely identify the anomaly. This code flashes until the anomaly is acknowledged pressing any push-button.
- A symbol that identifies the anomaly, see par. 10.5, 10.6 and 10.7.

Every fault uses two rows of the LCD display. The fault shown in the highest position is the most recent, chronologically. If space is not sufficient to show all the pending anomalies, only the most recent ones are shown. In order to see the others, it is required to:

- Press and keep press the button ▼.
- Use the ▲▼ pushbuttons to scroll the anomalies.
- At the end press and keep press the button ▲.

Some anomalies require the display of some additional information. For example, the anomalies 198 and 199 (cumulative of pre-alarms/alarms received via CAN-BUS from the electronic control units of the engines) also require the display of the single diagnostic codes. For every diagnostic code it is shown:

- The device that generated it (engine control unit or voltage regulator).
- The SPN code (it is a standard code defined by the SAE J1939 standard, which identifies the mechanical component that is having the problem).
- The FMI code (it is a standard code defined by the SAE J1939 standard, which identifies the type of problem).
- How many times this diagnostic code has been activated (OC).
- The alarm code specific for the external device connected (DTC).
- An alphanumeric description (in English) of the problem.

For some external device, the SPN, FMI and OC are not shown, but the DTC code and an alphanumeric description are always displayed.

If one or more of the above-mentioned information is not available, it will be replaced by dashes or it will simply not be displayed. If multiple diagnostic codes are active at the same time, they will be cyclically alternated on the display every 2 seconds. The diagnostic codes are stored (even if the external device deactivates them) until the yellow/red Can-Bus indicator light warning is acknowledged with the “ACK” button.

The additional information regarding the anomalies is shown on the last three lines of the display. If two or more anomalies are shown, to display the additional information is necessary to:





- Press the button ▼.
- Select the anomaly.

7.4.6.3 S.03 CONTROLLER

Page S.03 displays the specific information of the controller: date/time, alpha-numeric identification (ID Code) and firmware revision.

7.4.6.4 S.04 COMMUNICATION

Page S.04 displays the communication status on the USB port and on the CAN-BUS interface of the controller. From version 1.09, it also shows the communication status on the optional RS485 serial port. In case of operating problems, check the information contained on this page.

- USB: The status of the communication via USB is displayed through the symbols:
 -  Ongoing communication.
 -  Stand-by (no ongoing communication).
- COM: The status of the communication via the optional RS485 serial port is displayed through the symbols:
 -  Ongoing communication.
 -  Stand-by (no ongoing communication).
- CANBUS: There are three possible signalling:
 - - ERROR-ACTIVE: normal operation
 - - ERROR-PASSIVE: communication is working despite faults (errors).
 - - BUS-OFF: Gen-set has interrupted the connection to the bus due to too many errors.

The counters of the instantaneous transmission/reception errors and the maximum values reached are displayed. To reset the maximum values (and at the same time force the exit from the BUS-OFF status) it is necessary to:

- Keep button ▼ pressed: the counters will be highlighted.
- Press and hold the ▲ e ▼ buttons for five seconds.

7.4.6.5 S.05 DIGITAL INPUTS

Page S.05  displays the status:

- Of the digital inputs of the controller.
- Analogue inputs used as digital (if they are not used as digital, they are displayed with hyphens).

Pressing and holding the digit ▼ it is possible to display the turning inputs in two different ways:

- **LOGICAL STATE:** the controller shows the logic level of the inputs (active or inactive) used in the management of the operating sequence.
- **PHYSICAL STATE:** Electrical level (active or inactive, or high or low) actually present on the input; this can be the opposite in comparison to the corresponding logic state. Displayed in negative.

7.4.6.6 S.06 DIGITAL OUTPUTS

Page S.06  displays the status of the digital outputs of the controller. Pressing and holding the digit ▼ it is possible to display the turning inputs in two different ways:

- **LOGICAL STATE:** the controller shows the logic level of the outputs (active or inactive) used in the management of the operating sequence.

- **PHYSICAL STATE:** the controller displays the electric level (active or not active, high or low) really present on the input; it can be opposite compared to the corresponding logic status. Displayed in negative.

7.4.6.7 S.07 ANALOGUE INPUTS

Page S.07  displays the value of the analogue inputs of the controller **T.13**, **T.14**, **T.15**, of their reference terminal **T.12**, of **T.09** (D+) and of the analogue input **T.16**. For each input the measure in Volt is displayed, for terminals **T.13**, **T.14**, **T.15** the measure in ohm is also displayed.

7.4.7 Electrical measures (M.XX)

This mode displays all the information on the measurements taken by the controller on the electric lines. You can scroll through the various pages using ▲ e ▼ buttons.

7.4.7.1 M.01 SYSTEM

Page M.01 displays on a single line format the application diagram, highlighting:

- **The mains**  **The symbol is only displayed for Auto Mains Failure applications.** The symbol of the mains is fix if the mains is within the tolerance and flashing if the mains is missing or out of tolerance (see par. 9.2). Under it, the medium value of the three Mains unchained voltages and the Mains frequency measured by the device are shown.

 **INFORMATION!** If an external mains sensor is used (see par. 9.2.2) the symbol flashes or is fix according to the status of the external sensor, while the below measures are **always** those of the internal sensor of the device.

- **The generator**  The symbol of the generator is empty if the generator is idle, flashing with generator running but not supplying and it is shown “in reverse” (that is, full) when the generator is in supply conditions (see par. 9.3). Under it, the medium value of the three Generator unchained voltages and the Generator frequency measured by the device are shown.

- **The engine:**  The engine replaced the generator symbol if parameter P.0802 is set to "11-DRIVE ". The symbol of the engine is empty if the engine is stopped and it is shown “in reverse” (that is, full) when the engine is running. Under it, the engine speed is shown.

- **The loads**  The symbol of the load is displayed in “reverse” if the loads are powered from the mains or from the generator.

- The circuit breakers **GCB** and **MCB**. The symbol of the circuit breaker shows:
 - The open/closed status.
 - The difference between status and the breaker command (in this case the two contact points of the breaker flash).

If parameter P.0802 is set to "11-DRIVE ", the symbol of the circuit breaker is replaced by the symbol of a clutch.

- The power flows, displayed with arrows in the three branches of the system. The arrow points in the direction of the power. The arrow flashes (to indicate a faulty situation) in case of reversed power on the generator and in case of negative power to the loads.
- The active power measure and that of the power factor.

7.4.7.2 M.02 MAINS

 **INFORMATION!** The page is displayed only for Auto Mains Failure applications (see par. 0)

In fact, every digital input can have an AND/OR logic associated, which determines its status

This page shows the Phase-to-Phase concatenated voltages and the frequency of the generator, in addition to the rotation direction of the phases (clockwise or counter-clockwise). For three-phase systems, the phase-to-phase voltages are displayed; for the one-phase systems, the phase-to-neutral voltage and the voltage between neutral and negative battery are displayed and the rotation direction is not displayed.

To the bottom right there is an icon that allows immediate identification of the fact that the page is related to the MAINS measures.

This page is hidden if parameter P.0802 is set to "11-DRIVE".

7.4.7.3 M.03 MAINS

 **INFORMATION!** The page is displayed only for Auto Mains Failure applications (see par. 0) In fact, every digital input can have an AND/OR logic associated, which determines its status.

This page is only shown for the three-phase systems and only if the system is configured to use the neutral connection (see par. 5.9.1). In fact, every digital input can have an AND/OR logic associated, which determines its status. The three phase-neutral voltages are shown and the negative of the battery, in addition to the rotation direction of the phases (clockwise or counter-clockwise).

To the bottom right there is an icon that allows immediate identification of the fact that the page is related to the MAINS measures.

This page is hidden if parameter P.0802 is set to "11-DRIVE".

7.4.7.4 M.04 GENERATOR

This page shows the Phase-to-Phase concatenated voltages and the frequency of the generator, in addition to the rotation direction of the phases (clockwise or counter-clockwise). For three-phase systems, the phase-to-phase voltages are displayed; for the one-phase systems, the phase-to-neutral voltage and the voltage between neutral and negative battery are displayed and the rotation direction is not displayed.

To the bottom right there is an icon that allows immediate identification of the fact that the page is related to the GENERATOR measures.

This page is hidden if parameter P.0802 is set to "11-DRIVE".

7.4.7.5 M.05 GENERATOR

This page is only shown for the three-phase systems and only if the system is configured to use the neutral connection (see par. 5.10.1). In fact, every digital input can have an AND/OR logic associated, which determines its status. The three phase-neutral voltages are shown and the negative of the battery, in addition to the rotation direction of the phases (clockwise or counter-clockwise).

To the bottom right there is an icon that allows immediate identification of the fact that the page is related to the GENERATOR measures.

This page is hidden if parameter P.0802 is set to "11-DRIVE".

7.4.7.6 M.06 CURRENTS

This window displays the phase currents (three or only one for single-phase systems) of the Generator measured by the controller board.

This page is hidden if parameter P.0802 is set to "11-DRIVE".

7.4.7.7 M.07 POWERS 1

The active powers and power factors are shown, total and phase by phase (dashes only for phase 2 and 3 in single-phase mode). To the bottom right there is an icon that allows immediate identification of the fact that the page is related to the GENERATOR measures.

This page is hidden if parameter P.0802 is set to "11-DRIVE".

7.4.7.8 M.08 POWERS 2

This page shows the reactive powers (kvar), and the apparent powers (kVA) on individual phases and globally (for single-phase systems, the information related to phases 2 and 3 are replaced by dashes). To the bottom right there is an icon that allows immediate identification of the fact that the page is related to the GENERATOR measures.

This page is hidden if parameter P.0802 is set to "11-DRIVE".

7.4.7.9 M.09 ENERGY

This page shows the active and reactive power counters (partial and total) counted by the controller board when the loads are connected to the generator.

The active power is counted only if positive (it is not counted in the event of reversed power). The reactive power is counted in module (the counter goes up both with capacitive loads and with inductive loads).

On this page you can reset to zero the partial counters individually. To this purpose it is necessary to:

- Press and hold ▼: one of the counters will be highlighted.
- Use the vertical scrolling buttons ▲ and ▼ to select the counter you want to reset to zero.
- Press and hold the ▲ and ▼ for five seconds.
- Press and hold button ▲ to deselect the counter.

Attention: from version 01.08, if a password has been configured in parameter P.0001 ("user" protection level), it will not be possible to reset the counters until this password is entered (login) in parameter P.0000 (" Access code").

To the bottom right there is an icon that allows immediate identification of the fact that the page is related to the GENERATOR measures.

This page is hidden if parameter P.0802 is set to "11-DRIVE".

7.4.7.10 M.11...M.16 AVR

They contain a series of standard information (J1939-75) acquired via CAN-BUS from the automatic voltage regulator. The amount of information available depends on the type of device to which you are connected. Information not available is not displayed. The number of pages displayed therefore depends on the actual information transmitted by the voltage regulator. The information shown on these pages are:

- spn 1122 - Engine Alternator Bearing 1 Temperature.
- spn 1123 - Engine Alternator Bearing 2 Temperature.
- spn 1124 - Engine Alternator Winding 1 Temperature.
- spn 1125 - Engine Alternator Winding 2 Temperature.
- spn 1126 - Engine Alternator Winding 3 Temperature.

- spn 2436 – Average frequency
- spn 2437 - Frequency L1
- spn 2438 - Frequency L2
- spn 2439 - Frequency L3
- spn 2440 - Average L-L voltage
- spn 2441 - Voltage L1-L2
- spn 2442 - Voltage L2-L3
- spn 2443 - Voltage L3-L1
- spn 2444 - Average L-N voltage
- spn 2445 - Voltage L1-N
- spn 2446 - Voltage L2-N
- spn 2447 - Voltage L3-N
- spn 2448 – Average current
- spn 2449 - Current L1
- spn 2450 - Current L2
- spn 2451 - Current L3
- spn 2452 - Total active power
- spn 2453 - Active power L1
- spn 2454 - Active power L2
- spn 2455 - Active power L3
- spn 2456 - Total reactive power
- spn 2457 - Reactive power L1
- spn 2458 - Reactive power L2
- spn 2459 - Reactive power L3
- spn 2460 - Total apparent power
- spn 2461 - Apparent power L1
- spn 2462 - Apparent power L2
- spn 2463 - Apparent power L3
- spn 2464 - Total power factor
- spn 2465 - Power factor L1
- spn 2466 - Power factor L2
- spn 2467 - Power factor L3
- spn 2518 - Load type (total) (0=leading, 1=lagging)
- spn 2519 - Load type L1 (0=leading, 1=lagging)
- spn 2520 - Load type L2 (0=leading, 1=lagging)
- spn 2521 - Load type L3 (0=leading, 1=lagging)
- spn 2468 - Exported active energy
- spn 2469 - Imported active energy
- spn 3380 - Excitation voltage
- spn 3381 - Excitation current

7.4.7.11 M.17...M.22 AVR

From version 1.09, the controller supports the management of external configuration files that describe the Canbus communication with the automatic voltage regulators. These files may include the definition of one or more pages for the display, dedicated to displaying the specific measures/states of that device (usually when they do not follow the J1939-75 standard).



The controller offers up to six pages. The configuration file defines the number of measurements shown and their description.

7.4.8 Engine measurements (E.XX)

The engine related measurements are shown in this mode. The number of pages and the display of some parameters may depend on the type of engine (J1939, MTU or without communication interface). You can scroll through the various pages using ▲ e ▼ buttons.

7.4.8.1 E.01 ENGINE 1



It contains the fundamental measurements for engine management:

-  : Lubricating Oil pressure (bar).
-  : Coolant water temperature (°C).
-  : Rated engine speed (rpm)

If CANBUS connection is not available, it is possible to obtain the engine rotation speed by the generator frequency by inserting in parameter P.0127 the numeric ratio existing between frequency and speed. On normal four poles alternators, this ratio is 30 times higher than alternator frequency).

7.4.8.2 E.02 ENGINE 2

It contains other measurements for engine management:

-  : Starting Battery voltage (V) (measured by the controller).
-  : Fuel level in the tank (%).
-  : Type of CAN-BUS engine selected.

If any of these values is not available, it'll be shown with dashes.

7.4.8.3 E.03 ENGINE 3





It contains other quantities for the engine management, **when they are acquired using the analogue inputs of the controller**. If the same measurements are acquired using the CANBUS connection, they are displayed on other pages. This page is automatically hidden if none of the following measures are available:

- coolant level (AIF.1210 or AIF.1211 functions in the configuration of the analogue inputs).
- oil temperature (AIF.1100 or AIF.1101 functions in the configuration of the analogue inputs).
- oil level (AIF.1200 or AIF.1201 functions in the configuration of the analogue inputs).
- air temperature in the intake duct (AIF.1601 function in the configuration of the analogue inputs).
- turbocharger pressure (AIF.1641 function in the configuration of the analogue inputs).
- exhaust gas temperature (left bank) (AIF.1603 function in the configuration of the analogue inputs).
- exhaust gas temperature (right bank) (AIF.1605 function in the configuration of the analogue inputs).







If some of these measures are not available, they are hidden.

7.4.8.4 E.04 COUNTERS

This page contains various counters (managed by the controller board), which concern the engine:



-  Start-up counter (resettable to zero).
-   : Counter of operating hours (resettable to zero).
-   τ: Counter of operating hours (total, not resettable to zero).

The first four counters are resettable (individually). To reset a counter, the operator must:

- Press and hold : one of the counters will be highlighted.
- Use the vertical scrolling buttons  and  to select the counter you want to reset to zero.
- Press and hold the  e  buttons for five seconds.
- Press and hold button  to deselect the counter.

Attention: from version 01.08, if a password has been configured in parameter P.0001 ("user" protection level), it will not be possible to reset the counters until this password is entered (login) in parameter P.0000 (" Access code").

7.4.8.5 E.05 MAINTENANCE





This page contains the counter   of the hours left to the next maintenance managed by the controller (not resettable).

7.4.8.6 E.06 FUEL PUMP

See par. 11.1.

7.4.8.7 E.07 DASHBOARD

This page, as indicated by the title, shows all the standard warning lights (lamps) activated either by the engine control unit or by the automatic voltage regulator. This information is acquired via CANBUS. If none of this information is available, the page is not visible. The lamps displayed are:

-  SPN 1081 ("WAIT TO START LAMP"). It is necessary to wait for the engine control unit to finish the preliminary operations before the engine can be started.
-  SPN 624 ("AMBER WARNING LAMP"). The engine control unit (or the voltage regulator) is signalling on the CANBUS the presence of a diagnostic code (therefore of a problem) which at the moment does not prevent its operation.
-  SPN 623 ("RED STOP LAMP"). The engine control unit (or the voltage regulator) is signalling on the CANBUS the presence of a diagnostic code (therefore a problem) that prevents its operation
-  Indicates that the regeneration of the diesel particulate filter is inhibited following explicit command. It is usually displayed in solid yellow (it is a state, not an anomaly). If, however the condition remains for a long time and the soot level in the filter becomes extremely high, the ECU activates a diagnostic code with red lamp (icon with a STOP sign shape) and stops the engine: in this case the icon becomes red (fixed or flashing, like red lamp). It is linked to SPN 3697 ("DIESEL PARTICULATE

FILTER LAMP COMMAND”) or 6915 (“SCR SYSTEM CLEANING LAMP COMMAND”).

- 

• Indicates that regeneration of the diesel particulate filter is required. It is yellow. It is fixed (not blinking) if the quantity of particulate in the filter is above the "regeneration request" threshold but below the warning threshold. It becomes flashing if it is above the warning threshold. It is related to SPN 3703 (“DIESEL PARTICULATE FILTER ACTIVE REGENERATION INHIBITED DUE TO INHIBIT SWITCH”) or 6918 (“SCR SYSTEM CLEANING INHIBITED DUE TO INHIBIT SWITCH”).
- 

• SPN 3698 (“EXHAUST SYSTEM HIGH TEMPERATURE LAMP COMMAND”). It signals a high temperature (real or possible) in the emissions management system (HEST – High Emission System Temperature), probably because regeneration is in progress or about to start: the ECU could apply a reduction in engine performance (derating). It is yellow, not flashing.
- 

• SPN 5245 (“AFTERTREATMENT DIESEL EXHAUST FLUID TANK LOW LEVEL INDICATOR”). Indicates a low level of the Diesel Exhaust Fluid (DEF) tank. It can be steady if the level is below normal, flashing if the low level determines a power derating.
- 

• Indicates that the engine emissions system has a malfunction or is working outside the standard operating conditions. It is yellow, it can be fixed or flashing. It is related to SPN 1213 (“MALFUNCTION INDICATOR LAMP”) and 3038 (“FLASH MALFUNCTION INDICATOR LAMP”).

This page also shows all the diagnostic codes activated by the engine ECU or by the voltage regulator, **even if the controller is in OFF / RESET.**

Note: the controller forces this page to be displayed every time a lamp is activated.

7.4.8.8 E.08...E.18 CANBUS

They contain a series of standard information (J1939) acquired via CAN-BUS from the engine control unit. The number of information available depends on the type of control unit to which you are connected. Information not available is not displayed. The number of pages displayed therefore depends on the actual information transmitted by the engine control unit. The information shown on this page are:

- spn 22: Engine Extended Crankcase Blow-by Pressure
- spn 51: Engine Throttle Position.
- spn 52: Engine Intercooler Temperature.
- spn 81: Aftertreatment 1 Diesel Particulate Filter Intake Pressure
- spn 91: Accelerator Pedal Position 1.
- spn 92: Engine Percent Load At Current Speed.
- spn 94: Engine Fuel Delivery Pressure.
- spn 96: Fuel Level 1
- spn 98: Engine Oil Level.
- spn 100: Engine Oil Pressure.
- spn 101: Engine Crankcase Pressure.
- spn 102: Engine Intake Manifold #1 Pressure.
- spn 105: Engine Intake Manifold #1 Temperature.
- spn 106: Engine Intake Air Pressure
- spn 106: Engine Intake Air Pressure
- spn 107: Engine Air Filter 1 Differential Pressure

- spn 108: Barometric Pressure.
- spn 109: Engine Coolant Pressure.
- spn 110: Engine Coolant Temperature.
- spn 111: Engine Coolant Level.
- spn 132: Engine Intake Air Mass Flow Rate
- spn 156: Engine Injector Timing Rail 1 Pressure.
- spn 157: Engine Injector Metering Rail 1 Pressure.
- spn 158: Key switch Battery Potential.
- spn 166: Engine Rated Power.
- spn 168: Battery Potential / Power Input 1
- spn 171: Ambient Air Temperature.
- spn 172: Engine Intake 1 Air Temperature
- spn 173: Engine Exhaust Gas Temperature
- spn 174: Engine Fuel Temperature 1.
- spn 175: Engine Oil Temperature 1.
- spn 182: Engine Trip Fuel.
- spn 183: Engine Fuel Rate.
- spn 189: Engine Rated Speed.
- spn 190: Engine Speed.
- spn 247: Engine Total Hours of Operation.
- spn 249: Engine Total Revolutions
- spn 250: Engine Total Fuel Used.
- spn 411: Engine Exhaust Gas Recirculation 1 Differential Pressure
- spn 412: Engine Exhaust Gas Recirculation 1 Temperature
- spn 441: auxiliary temperature 1
- spn 442: auxiliary temperature 2
- spn 512: Driver's Demand Engine - Percent Torque.
- spn 513: Actual Engine - Percent Torque.
- spn 514: Nominal Friction - Percent Torque.
- spn 515: Engine's Desired Operating Speed.
- spn 544: Engine Reference Torque
- spn 977: Fan Drive State
- spn 1108: Engine Protection System Timer Override
- spn 1029: Trip Average Fuel Rate.
- spn 1127: Engine Turbocharger 1 Boost Pressure
- spn 1135: Engine Oil Temperature 2.
- spn 1136: Engine ECU Temperature.
- spn 1172: Engine Turbocharger 1 Compressor Intake Temperature
- spn 1180: Engine Turbocharger 1 Turbine Intake Temperature
- spn 1181: Engine Turbocharger 2 Turbine Intake Temperature
- spn 1182: Engine Turbocharger 3 Turbine Intake Temperature
- spn 1183: Engine Turbocharger 4 Turbine Intake Temperature
- spn 1241: Engine Fuel System 1 Gas Mass Flow Rate
- spn 1636: Engine Intake Manifold 1 Temperature (High Resolution)
- spn 1637: Engine Coolant Temperature (High Resolution)
- spn 1639: Fan Speed
- spn 2432: Engine Demand – Percent Torque

It is possible to reset spn 182 and 1029 (if displayed) directly in the engine control unit (if the ECU supports the command) by holding down the ▲ and ▼ keys within this page for 5 seconds.

Warning: from version 01.08, if a password has been configured in parameter P.0001 ("user" protection level), it will not be possible to reset the counters until this password (login) is entered in parameter P.0000 (" Access code").

7.4.8.9 E.19 DPF REGENERATION

From version 1.08, the controller fully supports the TIER4 (US) and STAGE V (EU) directives concerning generators emissions. This support consists of two parts:

- Visualization. A minimum of measurements is required:

- Percent of soot in the Diesel Particulate Filter (DPF).
- Percentage of ash in the Diesel Particulate Filter (DPF).
- Diesel Emissions Fluid (DEF) level.
- Icons (shown on page E.07)
- Commands. The specification provides two separate commands, to be sent to the ECU, to influence the regeneration of the DPF:
 - Inhibition of regeneration. This command should only be activated when the full power of the generator is required. Regeneration, in fact, involves temperature increases that may require a derating of engine performance. It should be a transient condition: if the level of soot in the filter increases and the ECU cannot regenerate it, at some point the ECU will still apply a derating and eventually it could stop the engine.
 - Forcing of regeneration. It is the opposite command: verifying from the previous lamps the request for regeneration from the ECU, the operator can force it in the moments more favourable to him.

The controller implements these commands in two ways:

- Parameter P.0446. This parameter can take three values:
 - 0 - Automatic. It does not send any commands to the ECU, which is therefore free to perform the regeneration whenever it wants.
 - 1 – Forced. It sends the forcing command to the ECU for a maximum of 10 seconds (then the parameter is reset to 0-Automatic). If the ECU can, it carries out a regeneration cycle, which involves overheating the emission treatment system and derating the engine. Following this command, some of the lamps described above can be activated.
 - 2 – Inhibited. It activates the ECU inhibition command, which therefore does not regenerate, even if required.

The parameter can be modified directly from page E.19.

- As an alternative to the parameter, it is possible to use two digital inputs configured with the following functions:
 - DIF.2071: inhibits regeneration.
 - DIF.2072: forces regeneration.

If there is one of the inputs, parameter P.0446 can no longer be changed, because the inputs go to force the value of the parameter.

You can also use virtual digital inputs to build complicated logics to manage the regeneration of the filter.

As a rule, the controller uses the Can bus line to send these commands to the ECU. It is also possible to use digital outputs, configured with the following functions:

- DOF.1035: regeneration inhibited.
- DOF.1036: regeneration forced.

The status of the two commands (forcing and inhibiting) is available for the AND/OR logics through the ST.137 and ST.138 states

Some ECUs, to perform the "active" regeneration of the particulate filter, must necessarily increase the engine speed. For this reason, they require consent from the controller before activating this process. The controller sends the consent to the "active" regeneration if the GCB circuit breaker is open.

Consequently, if the GCB is open and the ECU is performing the "active" regeneration (SPN3700 = 1), the maximum frequency / speed protections are disabled (by contact, by frequency measurement and by rpm measurement).

This page displays the fundamental states in the management of the filter regeneration and allows you to inhibit or force the regeneration of the particulate filter. In fact, it allows you to modify parameter P.0446 directly, without entering the programming menus.

The displayed statuses are:

- SPN 3701 ("AFTERTREATMENT DIESEL PARTICULATE FILTER STATUS"): indicates whether or not filter regeneration is required, based on the levels of ash and/or soot.
- SPN 3700 ("AFTERTREATMENT DIESEL PARTICULATE FILTER ACTIVE REGENERATION STATUS"). Indicates the status of the active regeneration process of the filter.
- SPN 3699 ("AFTERTREATMENT DIESEL PARTICULATE FILTER PASSIVE REGENERATION STATUS"). Indicates the status of the passive filter regeneration process.
- Status of the MANUAL regeneration process of the filter (only for SCANIA engines).
- All the causes that prevent the regeneration of the filter:
 - SPN 3702 ("DIESEL PARTICULATE FILTER ACTIVE REGENERATION INHIBITED STATUS")
 - SPN 3703 ("DIESEL PARTICULATE FILTER ACTIVE REGENERATION INHIBITED DUE TO INHIBIT SWITCH")
 - SPN 3711 ("DIESEL PARTICULATE FILTER ACTIVE REGENERATION INHIBITED DUE TO LOW EXHAUST TEMPERATURE")
 - SPN 3712 ("DIESEL PARTICULATE FILTER ACTIVE REGENERATION INHIBITED DUE TO SYSTEM FAULT ACTIVE")
 - SPN 3713 ("DIESEL PARTICULATE FILTER ACTIVE REGENERATION INHIBITED DUE TO SYSTEM TIMEOUT")
 - SPN 3714 ("DIESEL PARTICULATE FILTER ACTIVE REGENERATION INHIBITED DUE TO TEMPORARY SYSTEM LOCKOUT")
 - SPN 3715 ("DIESEL PARTICULATE FILTER ACTIVE REGENERATION INHIBITED DUE TO PERMANENT SYSTEM LOCKOUT")
 - SPN 3716 ("DIESEL PARTICULATE FILTER ACTIVE REGENERATION INHIBITED DUE TO ENGINE NOT WARMED UP")
 - SPN 3750 ("AFTERTREATMENT 1 DIESEL PARTICULATE FILTER CONDITIONS NOT MET FOR ACTIVE REGENERATION")

7.4.8.10 E.20...E.24 EXHAUST GAS THREATMENT

It contains a series of standard information (J1939) acquired via CAN-BUS from the engine control unit, concerning emissions management (AFTERTREATMENT). The number of information available depends on the type of control unit to which you are connected. Information not available is not displayed. The number of pages displayed therefore depends on the actual information transmitted by the engine control unit. The information shown on this page are:

- SPN 4765 ("AFTERTREATMENT 1 DIESEL OXIDATION CATALYST INTAKE TEMPERATURE")

- SPN 4766 ("AFTERTREATMENT 1 DIESEL OXIDATION CATALYST OUTLET TEMPERATURE")
- SPN 4781 ("AFTERTREATMENT 1 DIESEL PARTICULATE FILTER SOOT MASS")
- SPN 3719 ("AFTERTREATMENT 1 DIESEL PARTICULATE FILTER SOOT LOAD PERCENT")
- SPN 5466 ("AFTERTREATMENT 1 DIESEL PARTICULATE FILTER SOOT LOAD REGENERATION THRESHOLD")
- SPN 3720 ("AFTERTREATMENT 1 DIESEL PARTICULATE FILTER ASH LOAD PERCENT")
- SPN 3251 ("AFTERTREATMENT 1 DIESEL PARTICULATE FILTER DIFFERENTIAL PRESSURE")
- SPN 3242 ("AFTERTREATMENT 1 DIESEL PARTICULATE FILTER INTAKE TEMPERATURE")
- SPN 81 ("AFTERTREATMENT 1 DIESEL PARTICULATE FILTER INTAKE PRESSURE")
- SPN 3246 ("AFTERTREATMENT 1 DIESEL PARTICULATE FILTER OUTLET TEMPERATURE")
- SPN 3721 ("AFTERTREATMENT 1 DIESEL PARTICULATE FILTER TIME SINCE LAST ACTIVE REGENERATION")
- SPN 1761 ("AFTERTREATMENT 1 DIESEL EXHAUST FLUID TANK VOLUME")
- SPN 3031 ("AFTERTREATMENT 1 DIESEL EXHAUST FLUID TANK TEMPERATURE 1")
- SPN 3515 ("AFTERTREATMENT 1 DIESEL EXHAUST FLUID TEMPERATURE 2")
- SPN 3516 ("AFTERTREATMENT 1 DIESEL EXHAUST FLUID CONCENTRATION")
- SPN 5963 ("AFTERTREATMENT 1 TOTAL DIESEL EXHAUST FLUID USED")
- SPN 6563 ("AFTERTREATMENT TRIP DIESEL EXHAUST FLUID")
- SPN 4360 ("AFTERTREATMENT 1 SCR INTAKE TEMPERATURE")
- SPN 4363 ("AFTERTREATMENT 1 SCR OUTLET TEMPERATURE")
- SPN 4332 ("AFTERTREATMENT 1 SCR SYSTEM 1 STATE")
- SPN 4331 ("AFTERTREATMENT 1 DIESEL EXHAUST FLUID ACTUAL DOSING QUANTITY")
- SPN 4334 ("AFTERTREATMENT 1 DIESEL EXHAUST FLUID DOSER 1 ABSOLUTE PRESSURE")
- SPN 5246 ("AFTERTREATMENT SCR OPERATOR INDUCEMENT SEVERITY")
- SPN 3241 ("AFTERTREATMENT 1 EXHAUST TEMPERATURE 1")
- SPN 3236 ("AFTERTREATMENT 1 EXHAUST GAS MASS FLOW RATE")
- SPN 3237 ("AFTERTREATMENT 1 INTAKE DEW POINT")
- SPN 3238 ("AFTERTREATMENT 1 EXHAUST DEW POINT")
- SPN 3239 ("AFTERTREATMENT 2 INTAKE DEW POINT")

- SPN 3240 ("AFTERTREATMENT 2 EXHAUST DEW POINT")
- SPN 5826 ("EMISSION CONTROL SYSTEM OPERATOR INDUCEMENT SEVERITY")

7.4.8.11 E.25 ADBLUE PUMP

The page is available only if at least one digital output is configured to manage the pump for refilling the AdBlue fluid in the daily tank. It contains the following information:

- The current management mode of the pump (MAN-OFF, MAN-ON, AUTO).
- The status of the pump (on/off).
- An indication of the AdBlue fluid level, referred to the pump management (start required, stop required, in hysteresis).

If the pump management is linked to the analogue measurement of the level in the tank (SPN 1761 SAE J1939), then the controller displays the current level with a graphic bar, also indicating the start/stop thresholds of the pump.

It is possible to change the pump management mode from this page, without having to go to programming. To do this, you must:

- Press and hold button ▼: the icons that identifies the current mode will be shown in negative.
- Use the vertical scrolling buttons ▲ and ▼ to select the desired mode.
- Confirm keeping button ▼ pressed or cancel the modification pressing and holding ▲.

See 11.13 for a detailed description of the functions offered by the controller for the control of this pump.

7.4.8.12 E.25...E.30 CANBUS

From version 1.07, the controller supports the management of external configuration files that describe the Canbus communication with the electronic engine control units. Such files may include the definition of one or more pages for the display, dedicated to displaying the measurements/states specific to that control unit (usually when they do not follow the J1939 standard). For example, if you use the files related to MAN DATALOGGER, the controller displays all the measurements acquired by those units in a single page.

The controller provides up to six pages. The configuration file defines the number of measures shown and their description.

7.4.8.13 E.31 EXTERNAL MEASURES

This page is dedicated to the measures acquired by the analogue inputs configured as "generic sensor". The operator can acquire the measures not related to the controller operation and display them.





The controller shows one measure per line: it shows the text configured for analogue input (P.4010 analogue input T.13), followed by the measure.

7.4.9 History logs (H.XX)

When in operation and not in **OFF/RESET**, mode, the controller performs periodical or on-event recordings that can be partially configured with programming parameters.

The history logs are downloadable via PC through USB connection.

The controller manages four types of archives:

#	Description	Icon	ID:	Max
1	Events		H.09	64
2	Fast Analogues		H.15	64
3	Slow Analogues		H.21	42
4	DTC-ECU-AVR		H.27	16

In this way, information on the system status is provided. You can scroll through the various pages using ▲ e ▼ buttons.

The archives are accessible only from the browsing menu among the modes.

To enter archive's view, after selecting icon, it is necessary to  hold the button ▼ pressed until the base page of the HISTORY LOGS is displayed (H.03).

When in a mode limiting the use of vertical scroll buttons you may require pressing repeatedly button ▲.

When the procedure starts, the menu is shown with different archive functions.

7.4.9.1 Log selection

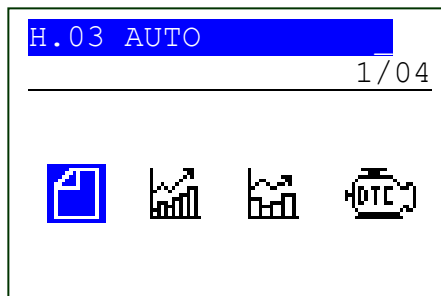

The first line always shows the numerical indication of the selected function and the number of functions in the menu. The following display lines are used in order to show the selectable functions.

The selected voice is highlighted in negative (REVERSE).

Use the ▲ and ▼ buttons to cyclically scroll through the menu to the lower and upper index items (i.e., pressing the ▲ allows to directly cycle from the first item to the last one).

Keeping button ▼ pressed, the selected function activates (the one highlighted in negative); keeping button ▲ pressed you return to page "H.03".

























7.4.9.2 Events pages ()















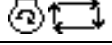
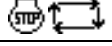
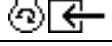



Events: at the time when an event (previously configured) occurs, the board adds a record in this archive. The capacity is of 64 records. If the archive is full and a new event occurs, the less recent is overwritten (so always the last 64 events are stored). For each event are recorded, in addition to the numeric code, also the date/time in which the event occurred, the operation mode of the controller, the engine, the generator, the mains and the change-over in

that moment. If the event is an anomaly, measures described for the analogue archives are also stored. The configuration of which event to be recorded is possible by means of parameter **P.0441** with a bit management:

Bit	Value P.0441	Ver.	Description
0	1	1.00	Controller mode.
1	2	1.00	Mains statuses.
2	4	1.00	Generator statuses.
3	8	1.00	Engine statuses.
4	16	1.00	MCB and MGCB statuses.
5	32	1.00	MCB and MGCB commands.
6	64	1.00	Start/stop requests.
7	128	1.00	Fuel pump controls.

The following table lists all possible event codes.

Code	Icon	Versio	Recording cause
EVT.1001		1.00	OFF_RESET
EVT.1002		1.00	MAN
EVT.1003		1.00	AUTO
EVT.1004		1.00	TEST
EVT.1005		1.00	REMOTE START
EVT.1010		1.00	Mains failure (flashing)
EVT.1011		1.00	Mains live (out of tolerance)
EVT.1012		1.00	Mains in tolerance
EVT.1013		1.00	Inhibition activated (from configurable input)
EVT.1014		1.00	Inhibition not activated (from configurable input)
EVT.1020		1.00	Generator failure
EVT.1021		1.00	Generator on
EVT.1022		1.00	Generator in tolerance
EVT.1030		1.00	GCB Close command
EVT.1031		1.00	GCB Open command
EVT.1032		1.00	GCB closed (from digital input)
EVT.1033		1.00	GCB open (from digital input)
EVT.1035		1.00	MCB Close command
EVT.1036		1.00	MCB Open command
EVT.1037		1.00	MCB closed (from digital input)
EVT.1038		1.00	MCB open (from digital input)
EVT.1040		1.00	Engine idle
EVT.1041		1.00	Starting cycle
EVT.1042		1.00	Engine running

EVT.1043		1.00	Cooling cycle
EVT.1044		1.00	Stopping cycle
EVT.1050		1.00	Manual start-up command
EVT.1051		1.00	Manual stop command
EVT.1052		1.00	Auto start command
EVT.1053		1.00	Auto stop command
EVT.1054		1.00	TEST mode requested by digital input.
EVT.1056		1.00	Command for start in TEST mode from serial port
EVT.1058		1.00	Command for start in TEST mode from clock/calendar
EVT.1062		1.00	Starting command for failure to close MCB.
EVT.1070		1.00	Fuel pump on
EVT.1071		1.00	Fuel pump off
EVT.1072		1.14	AdBlue pump on
EVT.1073		1.14	AdBlue pump off
EVT.1074		1.00	Reset
EVT.1075		1.00	Clock/Calendar not valid (but used by some functions)
EVT.1076		1.00	Date/time update
EVT.1077		1.00	New controller power-on
EVT.1078		1.00	Default values of the parameters recharged
EVT.1079		01.01	Active energy saving.

Active energy saving.

Anomalies are themselves saved as events. They are registered with their own alarm code summed to:

- **EVT.2000**: if they are warnings.
- **EVT.4000**: if they are deactivations.
- **EVT.5000**: if they are interlocks.

When displayed, the value 2000, 3000, 4000 or 5000 is removed and replaced by the letter "W", "D" or "A" before the alarm code.

For example, by simulating an emergency stop event, we will obtain, in the archive window, a view of this type: 0048: A048 Emergency stop. The same event, read via USB, will be identified with the view: 5048, where the thousands figure will identify the type (5 = interlock), followed by the code of the cause (048= Emergency stop).

For a complete list of the anomaly codes, see [1].

To display every event, the controller uses at least three pages of the display: if the event displayed is one of the 21 most recent anomalies, it uses seven pages. The main page has the following format:

H.09	OFF	
		15/44
<hr/>		
17/03/2014	14:37:55	
▶		0024
⚡ⓐ		W024

The second line of each event page shows what event is currently displayed (15) and any partial event stored (44). Once the total number of events available is reached, the partial value will remain fixed at the limit value (64) up to a possible log resetting. The example in the previous figure shows event 15 of 44 stored (out of 64 available).

The fourth line of each event page displays the date/time of the record; on the right it also displays two arrows indicating the availability of further pages to the right or to the left of the current page for the current event.

The lines from the fifth to the eighth show different information, depending on the selected page.

- The first page shows the numerical code of the event ("0024" in the given example) and one or more icons which identify the event ("W024 GCB closed").
- The system status when the event was recorded are displayed in the second page: the controller operation modes, as well as engine status, generator status, mains status and change-over status.
- The third page shows the communication status (GCB and MCB) when the event was recorded.
- Pages from the fourth to the seventh are described in the analogues log.

The most recent event is associated to the highest number. Using the ▲ and ▼ pushbuttons it is possible to scan all the records.

Keeping button ▼ pressed, the navigation through the pages linked to the single event activates (the number that identifies the event e the number of the recorded events begin to flash). At this point, using the ▲ and ▼ pushbuttons it is possible to cyclically scan all the pages. To select another event, keep ▲ pressed.

7.4.9.3 Pages for analogues

With a configurable rhythm through parameter P.0442 (interval in seconds) and P.0443 (in minutes) the controller records the following analogue magnitudes:

- Mains phase-to-phase voltages and frequency.
- Generator frequency and phase-to-phase voltages.
- Generator currents.
- Active, reactive, and apparent powers, the power factor, and the type of load.
- Starting battery voltage, engine rotation speed, coolant temperature, oil pressure and engine fuel level.

Each record is associated with its date/time. The measurements that are not acquired (because the controller is configured not to acquire them) are replaced by some display hypens.

To display all records, the controller uses four pages of the display. The main page has the following format:

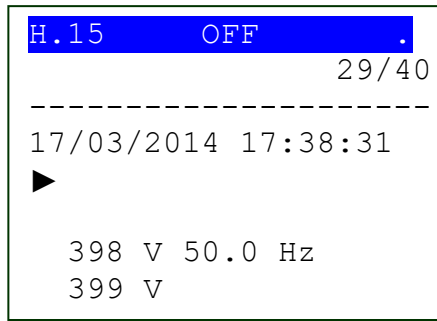

The second line of each page shows what record is currently displayed (29) and any partial record stored (40). Once the total number of records available is reached, the partial value will remain fixed at the limit value up to a possible log resetting. The example in the previous figure shows record 29 of 40 stored (out of 42 available).

The fourth line of each page displays the date/time of the record; on the right it also displays two arrows indicating the availability of further pages to the right or to the left of the current page for the current record.

The lines from the fifth to the eighth show different information, depending on the selected page.

- The first page displays all the values of the mains/bars, at the time of recording: frequency and voltage
- The second page displays all the values of the generator, at the time of recording: frequency and voltages
- The third page displays all the values of the load, currents and powers, at the time of recording: currents, apparent power, active and reactive power, power factor.
- The fourth page displays all the values of the engine, at the time of recording: battery voltage, Engine speed oil pressure, Oil pressure, Coolant temperature, Fuel level

The more recent record is the one associated to the highest number. Using the ▲ and ▼ pushbuttons it is possible to scan all the records.

Keeping button ▼ pressed, the navigation through the pages linked to the single record activates (the number that identifies the event e the number of the recorded records begin to flash). At this point, using the ▲ and ▼ pushbuttons it is possible to cyclically scan all the pages. To select another record, keep ▲ pressed.

7.4.9.4 Fast analogues logs

The fast analogues are recorded at a pace configurable by means of parameter **P.0442** (interval in seconds) and the default interval is 60 seconds. This archive can store up to **42** records. Every following record overwrites the older one. The controller records the analogue values described in par. 0.

7.4.9.5 Slow analogues logs

The slow analogues are recorded at a pace configurable by means of the parameter **P.0443** (interval in minutes) and the default interval is 30 minutes. This archive can store up to **64** records. Every following record overwrites the older one. The controller records the analogue values described in par. 0.

7.4.9.6 Locked recordings

Analogue and events recordings are temporarily OFF when in “OFF/RESET” mode.

When the records are blocked, on the second line a lock is displayed  before the partial number of events or records in all windows of the history log. In this situation, the counter inside the controller keeps on decreasing the time for the time limit of the next recording.

When the operation mode shifts from “OFF/RESET” to “MAN” or “AUTO” mode, a check is performed in order to verify whether some recording counter expired. If so, the recorded date and time of the status change are stored, otherwise the count continues till the next recording is stored.

7.4.9.7 Diagnostics pages for external devices connected by Canbus (DTC)

The controller records the diagnostic codes that the engine control unit (ECU Interface) and the voltage regulator (AVR) send on the CAN-BUS line.

Basically, depending on the connected external device, the diagnostic message consists of the DTC, SPN and fault description. This archive can store up to 16 records. Every following record overwrites the older one.

To display all records, the controller uses one page of the display.

```

H.27 HISTORY LOGS |
                    16/16
-----
17/03/2014 14:27:12
VOLVO EMS2 (0)
DTC:6.6 SPN:100 1 2
Engine oil pressure
Data low (shutdown)
  
```

The second line shows the record currently displayed, out of the total number of records (the maximum number of records is 16).

The fourth line shows the recording date and time.

The fifth line identifies the external device that triggered the diagnostic code.

The sixth line shows the diagnostic code. It contains:

- DTC (Diagnostic Trouble Code): it is a non-standard diagnostic code, specific to the connected external device, which can be found in the technical manual of the external device (in the example, the code "6.6" in the engine technical manual will describe the low oil pressure problem).
- SPN (Suspect Parameter Number): is a numeric code showing the engine part/component that generated the diagnostic code (in the example, "100" identifies oil pressure measure).
- FMI (Fault Mode Identifier): is a numeric code between 0 and 31 that identifies the kind of problem (in the example, "1" indicates an excessively low value of the measure, thus requiring engine stop).
- OC (Occurrence Count): indicates how many times this diagnostic code has already been activated (example "2").

In addition, if the combination of the SPN and FMI codes (or the DTC code) is known to the controller, a text description of the problem is displayed.

The more recent record is the one associated to the highest number. Using the ▲ and ▼ pushbuttons it is possible to scan all the records. The controller uses only one page of the display for this type of recordings.



7.4.9.8 Exit from archives visualization

To exit the logs' view, keep digit ▲ pressed several times until you go back to the mode's navigation menu.

7.4.9.9 Reset archives to zero

To reset an archive to zero, it is necessary to display it first and then to keep the digits ▲ and ▼ for 5 seconds, until when the controller shows a message of reset to zero.

8 Parameter's programming

⚠ WARNING: Assigning an incorrect value to one or more parameters can cause malfunctions, damage to things or injury to people. The parameters must only be changed by qualified personnel. Parameters can be password protected (refer to par. 8.5).

i INFORMATION! The controller manages a high number of parameters that allow the manufacturer, the installer or the final user to configure it in order to adapt it to specific system requirements. This document does not contain the parameters list (even though many of them are quoted in the description of the controller functions); the list is available in the documents [1] where they're described in detail.

⚠ ATTENTION! Some functions or particular configurations can be settable or modifiable only through the PC program SICES Board Programmer3. The use of BoardPrg4 is recommended as it simplify a lot the programming operations.

In this paragraph the general programming structure and the operating procedure to read and/or modify parameters are described. You can use the device keyboard for this.

i INFORMATION! The modification of some parameters can be password protected (see par. 8.5)

i INFORMATION! The programming by means of the device keyboard is only possible with controller in OFF-RESET and engine idle.

8.1 Access to programming menu

The access to the programming modes of parameters can be done from any page **only with controller in OFF/RESET**, keeping pressed at the same time digits **STOP** and **AUTO** for at least one second.

i INFORMATION! When programming, digits **STOP**, **AUTO** and **START** have a different function and cannot be used to modify the operation mode of the controller and to control the engine.

To exit programming menu and to return to the main screen press the **STOP**.

At the beginning of the procedure, the main menu is always shown.

P.01	OFF	
Main menu		1/06
1	System	
2	Sequence	
3	Protection	
4	Aux. functions	
5	Communication	
7	Canbus	

- **1 (SYSTEM):** Menu 1-SYSTEM allows to show how the controller connects to the engine and to the generator and the kind of application. Correct setting of these parameters is paramount as almost all protection activation thresholds are expressed as a percentage of these parameters.
- **2 (SEQUENCE):** Working sequence configuration can be modified through the menu 2-SEQUENCE. In this menu it is possible to set threshold percentages and acquisition times, plus enabling/disabling operation sequences related functions.
- **3 (PROTECTION):** Protections management is accessible through the menu 3-PROTECTION. As to this, it is important to know that, in order to enable/disable a protection, you may simply modify the associated time, leaving the threshold unchanged: by setting the time to zero, the protection is disabled. However, this general rule provides some exceptions. Refer to chapter dedicated to anomalies, par. 0, which describes the deactivation mode for each one.
- **4 (AUXILIARY FUNCTIONS):** All operations not related to system, sequence and protections configuration, can be performed through the menu 4- AUXILIARY FUNCTIONS. This menu contains other menus used for configuring engine auxiliary functions, history logs and serial communication.
- **5 (COMMUNICATION):** This menu configures the communication via USB
- **7 (CAN BUS):** This menu allows you to configure how the controller will communicate on the bus to acquire measurements, diagnostic codes and possibly to send commands to the engine control unit (ECU) and/or to the automatic voltage regulator (AVR).

8.1.1 Menu selection

Current menu name, selected menu item and number of menu items are always displayed in the second line. Menu items (sub menus) are displayed in the following lines. The item selected is displayed in REVERSE. Use the ▲ and ▼ buttons to cyclically scroll through the menu to the lower and upper index items (i.e., pressing the ▲ allows to directly cycle from the first item to the last one).

Pressing digit **AUTO**, you enter the sub menu selected (highlighted); pressing **STOP** you leave the menu (back to the previous menu or to the base screen if exiting programming in the main menu).

8.2 Parameter organization

KEY:

- 1 - Status bar
- 2 - Current menu
- 3 - Current parameter
- 4 - Parameter value

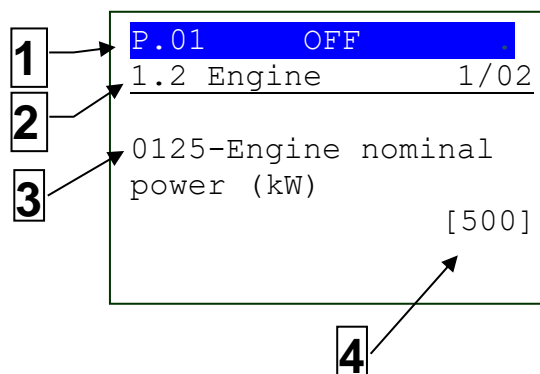

Fig. 1 - Display areas

Entering the programming mode of each single parameter, page of fig. 1 is shown.

Each programming parameter (Ref. 3) has a 4-digit numeric code (e.g., P.0125) to identify the variables regardless of the language used. The current value of the parameter is displayed below the description Ref.4.

The first line under the superior status bar, allows to identify the current menu (Ref. 2) through the identification number of the menu and the matching text. A pair of numbers is displayed

on the right of this line, 1/ 02 in the example in fig. 1. The first indicates which entry of the menu is selected or which page is displayed, the second indicates how many entries or pages can be displayed in the present menu/sub menu.

8.2.1 Parameter's selection

The name of the current menu (in the example the menu "1-SYSTEM") is always shown in the first line, followed by the numeric Id of the selected item and the number of menu items. The following lines are used to display single parameters. In detail:

- Fourth and fifth rows show the univocal parameter code (four decimal digits) followed by the description in the current language.
- The sixth line shows the variable value, between brackets, aligned to the right side "< >".
- For some parameters, on the eighth line, a value is shown, which is in some way related to the actual parameter value. For example, in the case of the rated generator power, the rated generator current is shown, derived from the rated generator voltage (P. 0102) and from the parameter itself (rated power, P.0106). Sometimes, this additional measure can be displayed for showing its absolute value, when the parameter is a percentage of other values.

Use the ▼ and ▲ buttons to cyclically scroll through the menu to the lower and upper index items (i.e., pressing the ▲ allows to directly cycle from the first item to the last one and vice versa). Press the **AUTO** button to enable the parameter modification procedure (see following paragraph). Press the **STOP** button to leave the menu (back to the previous menu).

8.2.2 Modify a parameter

You may only modify parameters displayed between square brackets ([]). A parameter between (major/minor) symbols "<>" cannot be modified. In this case it could be necessary to set an appropriate password. or stop the genset.

In case modifying the displayed parameter is allowed, press the **AUTO** button; the square brackets ([]) enclosing the value will blink to signal that the modification is in progress. To confirm the new value, press again the **AUTO** button; to abort and return to the original value, press **STOP** button.

Parameter types are the following:

- **Numeric**: the value can be modified by pressing the ▲ ▼ buttons, in order to increase or decrease one unit (if you press the above buttons plus **AUTO**, the figure will be increased or decreased by ten units at a time). The change is cyclical: increasing over the maximum value when will lead to the minimum one and vice versa.
- **Numeric with a selection among a predefined list** (e.g., The number of phases of the generator): it is valid what said for the numeric parameters, considering that digits ▲ ▼ allow to pass to the following/previous value in the predefined list (with digit **AUTO** you pass to the following/preceding value by ten positions).
- **Numeric selected in a number-string couples list** (e.g., the type of pressure sensor): same as the previous point.
- **Time**: same as numerical parameters, with one exception: the controller manages the increment/decrement maintaining valid values (example: increasing from "00.59", the value goes to "01.00" and not to "00.60").
- **Strings** (e.g., Plant name): in this case the display shows (in reverse) the currently selected character in the string. Buttons ▲ ▼ act on the selected character (passing to the following/previous of the ASCII chart or to the one that follows/precedes it by ten positions, if also pressed **AUTO**), while buttons **STOP** and **START** allow to select the character to be modified. **You can set the ASCII characters from 32 (Space) to 127 (Escape). It is not possible to set extended ASCII characters (over 127) and the control ones (from zero to 31).**

- **Bits:** Some parameters are managed in bit. Each bit at 1 enables a function and each bit at 0 disables a function. Each bit is assigned a value. The parameter must be set as the result of the sum of the values associated to the functions you require to enable. 8 bits can be used. The description of these parameters is shown in a table like the one below:

Bit	Value	Description
0	1	Enable function 1
1	2	Enable function 2
2	4	Enable function 3
3	8	Enable function 4
4	16	Enable function 5
5	32	Enable function 6
6	64	Enable function 7
7	128	Enable function 8

If the operator wants to:

- Disable all functions: you must set 0 in the related parameter.
- Enable all functions: the value to set is given by the sum $1+2+4+8+16+32+64+128 = 255$.
- Enable, for example, functions 3, 4, 6 e 8: the value to set is given by the sum $4+8+32+128 = 172$ (where 4 is the value associated to function 3, 8 to function 4, 32 to function 6 e 128 to function 8).

Attention: the value must be set with the hexadecimal noting:

- 255 → FF
- 0 → 00
- 172 → AC

8.2.3 Set up limits

The operator has not to worry about verifying that the set-up value is acceptable for the controller since it is not possible to set up not acceptable values.

This goes for individual parameters; however, it is possible to set two or more parameters in incongruent or incompatible ways. It is up to the operator to prevent this from occurring.

8.3 Exit from programming

To exit the programming, press button **STOP** n times to scroll back to the main menu, then press it again to exit programming. On the following access to the programming the main menu will be shown.

8.4 Loading default values

 **WARNING: This procedure permanently reloads all factory parameters according to access rights.**

Sometimes, it may be useful to reload parameters factory values. To do so, it is first of all necessary to select **OOFF/RESET** mode, access programming, and then press and hold ▲ e ▼. Reload of factory values will be confirmed by a message on the display. **Factory values are reloaded only for parameters for which you are granted access rights.**

8.5 Protection password

Access to programming mode can be controlled through 3 different PASSWORD levels, here listed in priority order:

- Maker password
- System password
- User password

Each parameter of the controller board is associated to a protection level (in documents [1] this association is shown in the "ACC" column where "C" stands for Manufacturer, "I" for Installer and "U" for the End User).

A parameter associated to the manufacturer level can be only modified using the manufacturer password. A parameter associated to the installer level can be modified by the manufacturer and the installer. A parameter associated to the end user level can be modified by the manufacturer, the installer, and the end user.

The general rule says that the parameters are modifiable only when the controller is in "OFF/RESET" mode.

The operator who has to modify a parameter, has first of all to let himself be recognised by the controller as "manufacturer", "installer" or "user" by entering the proper password in parameter P.0000 (menu "1.1.1 - Authentication", path "1. System\ 1.1 Security\ 1.1.1. Authentication"). After this operation, he can modify the parameters, limited to those he can enter according to his password level. The access code entered remains saved in P.0000 for about 10 minutes since the end of programming. After this time, the code is automatically reset to zero and must be re-entered to access programming again.

It is possible to customize the passwords through parameters P.0001 (manufacturer), P.0002 (installer) and P.0003 (end user), available in the menu "1.1.2 Password", path "1 System\ 1.1 Security\ 1.1.2 Password". The "0" value for these parameters indicates not set password.

If a password gets lost, it is possible to reconfigure it by logging in with the higher-level password. This is the reason why we recommend setting at least the "Manufacturer" password (P.0001): actually, in case someone else sets up this password, or a lower level one (even unwillingly) without providing information, no parameter modification will be possible any more. On the contrary, if you know the "manufacturer" password, it will be in any case possible to cancel or modify the other passwords. In case you lose the "manufacturer password" it is necessary to contact MECC ALTE service centre.

The following examples show all combinations of passwords assignation.

Example 1: P.0001 =0 P.0002 =0 P.0003 =0

Any operator is seen as a "manufacturer", with no need of setting anything in P.0000. Therefore, all parameters, except for the special ones, can be changed by anyone (this is the default mode).

Example 2: P.0001 =0 P.0002 =0 P.0003 =UUU

No parameter is modifiable. When the user enters the "UUU" code in P.0000, he would be considered "user", but as no password is associated to the "installer" and the "manufacturer", the controller considers him as "manufacturer". After entering this code, all parameters, except for the special ones, can be modified.

Example 3: P.0001=0 P.0002 =III P.0003 =UUU

No parameter is modifiable. When the user enters "UUU" in P.0000, he is considered "user" and can modify only the parameters associated to "user". If user enters "iii" the board considers it "manufacturer" because there is no password for "manufacturer". After entering this code, all parameters, except for the special ones, can be modified.

Example 4: P.0001=CCC P.0002 =III P.0003 =UUU

No parameter is modifiable. When the user enters “UUU” in P.0000, he is considered “user” and can modify only the parameters associated to “user”. If the user enters “III”, he can modify all parameters associated to “installer” and “user”. When entering “CCC”, the operator is identified as “manufacturer” and is therefore allowed to modify any parameter of the controller board.

Example 5: P.0001=CCC P.0002 =0 P.0003 =0

No passwords are associated to the user and the installer. The parameters associated to user and installer are free programmable, without entering any code in P.0000. To modify manufacturer associated parameters you have to enter “CCC” in P.0000.

Example 6: P.0001=0 P.0002 =III P.0003 =0

As no password is associated to the user, the parameters associated are freely programmable, without entering any code in P.0000. When the user enters “III” in P.0000, he can modify all parameters because there is no password for “manufacturer”. After entering this code, all parameters, except for the special ones, can be modified.

Example 7: P.0001=CCC P.0002 =III P.0003 =0

As no password is associated to the user, the parameters associated are freely programmable, without entering any code in P.0000. When the user enters “III” in P.0000, he can modify all parameters associated to “installer” and “end user”. When entering “III” in P.0000, the operator is identified as “manufacturer” and is allowed to modify all parameters, excluding critical ones.

Example 8: P.0001=CCC P.0002 =0 P.0003 =UUU

No parameter is modifiable. When the user enters the “UUU” code in P.0000, the controller considers him “user”, but as no password is associated to “installer”, it considers him “installer”. He is able to modify all parameters associated to the end user and the installer. When entering “III” in P.0000, the operator is identified as “manufacturer” and is allowed to modify all parameters, excluding critical ones.

The parameter value can be read, but the modification can be carried out only if P.0000 contains a proper password. Parameters P.0001, P.0002, P.0003 and P.0003 are excluded: actually, they are not displayed in case P.0000 does not contain a proper password.

8.5.1 Password for commands from serial port (USB)

An extra password exists, which is managed through parameter P.0004. Its role is to avoid that any commands can be sent to the device through communication via USB with Modbus protocol. To send commands via Modbus to the device, it is necessary that each command is preceded by the password contained in P.0004. The default password is “123”.

9 Operation sequence

9.1 Operating mode

There are five device management modes:

- **OFF/RESET:** the genset is off (or in the arrest phase), the anomalies are all cancelled, and you can access the programming to modify the parameters. The GCB switch is open to isolate the generator from the loads. The MCB breaker is closed to connect the loads to the mains.
- **MAN:** genset start and stop, and also the management of GCB and MCB circuit breakers (if present and if configured) are to be performed by the operator (the controller board does not perform these operations automatically): the protections being enabled, the controller can automatically open GCB, stop the genset and close MCB (if present) in case of need. The access to the programming is not allowed.
- **AUTO:** genset start/stop and the management of the GCB and MCB breakers are performed by the controller board (the operator cannot interfere). All protections are enabled. The access to the programming is not allowed.
- **TEST:** this working mode is almost identical to **AUTO**. The only difference is that the engine is anyway (automatically) started even with mains and/or automatic intervention inhibition contact ON. The parameter P.0222 “Enabling test loading”, allows indicating to the controller if it must automatically change-over the loads to the generator. In any case, the operator is authorized to control the MCB and GCB breakers just like in **MAN**. When the controller goes back to **AUTO** mode (when the test is finished), the loads are automatically changed over to the mains and the engine is stopped with normal procedure. The controller automatically switches from **TEST** to **AUTO** in case existing conditions require an automatic intervention by the genset. The access to the programming is not allowed.
- **REMOTE START:** this working mode is almost identical to **AUTO**. It only differs for the fact that the engine is started in any case (automatically), even with mains live and/or inhibitions to the automatic intervention; the controller automatically provides for the GCB circuit breaker closure (prior to opening of MCB, if the temporary parallel with the mains is not considered). Such mode is priority compared to **TEST** (that is, it can interrupt or swap with the periodic test). It is also priority compared to **AUTO** (once activated the remote start, any requests of automatic intervention are ignored). The operator doesn't have power to manually activate GCB and MCB circuit breakers. The access to the programming is not allowed.

The operating mode can be selected in two different ways:

- Using buttons “**STOP**”, “**AUTO**” and “**START**” of the controller. The buttons must be pressed consecutively and held for at least half a second to force mode change. The buttons are disabled (on the first line of the display a key-shaped icon appears) if at least one of the inputs described below exists and is active.
- Using one or several inputs configured with the following functions:
 - DIF.2271 “OFF by remote control”.
 - DIF.2272 “MAN by remote control”.
 - DIF.2273 “AUTO by remote control”.

When one of these inputs is active, the operating mode of the controller is forced and you can no longer use the buttons on the panel, nor the controls of the serial ports to change it (the first line of the display shows a key-shaped icon).

When neither of these inputs is active, you are again able to use the buttons and the controls of the serial ports to change the operating mode.

If there are multiple active inputs at the same time, priority is given to the input that forces **OFF/RESET** mode, followed by the one that forces **MAN** mode and finally the one that forces **AUTO** mode.

You needn't use all three inputs. For example, you can use a single input to force **AUTO** status: when the input is active the controller is always in **AUTO** mode, and when it is deactivated, the controller remains in **AUTO** mode, but you can use the buttons to change-over to **MAN** or **OFF/RESET**.

If only one input is used to force OFF/RESET mode, the controller acts differently: when the input is active, the controller is always in OFF/RESET mode, and when the input goes back on standby, the controller goes back to the mode it was in prior to input activation.

- Sending Modbus commands through USB port. The command is only managed if none of the above-described inputs is active. Parameters can be password protected (P.0004, refer to par. 8.5.1) which has to be sent before every command. To send the command to change mode, it is necessary to write in sequence (within 5 seconds):
 - HOLDING REGISTER 101: write the password configured with the parameter P.0004.
 - HOLDING REGISTER 102: write the value:
 - “1” to require mode **OFF/RESET**.
 - “2” to require mode **MAN**.
 - “3” to require mode **AUTO**.

To enable the **TEST** mode requires the controller being first set to **AUTO** w/o any automatic start request (refer to the engine sequence description). All possible **TEST**. function activation modes are described below. **TEST** mode is indicated by means of a flashing spy **AUTO** on the panel (50% on - 50% off). You can shift to **TEST** mode as follows:

- By properly configuring the parameters:
 - P.0418: Test enable days.
 - P.0419: Test start time.
 - P.0420: Test duration.

These parameters allow for weekly programming of the time intervals for **TEST** mode engine start (to keep it efficient). In this case, the passage to **TEST** is automatic in the scheduled days and hour. The controller returns to **AUTO** when the **TEST** time interval ends.

- From a PC connected with a USB port (with protocol Modbus RTU). The controller shifts to **TEST** after receiving the command, then, returns to **AUTO** after receiving the opposite command or when it detects an interrupted serial connection (60 seconds w/o messages). Parameters can be password protected (P.0004, refer to par. 8.5.1), which has to be sent before any command, and can be disabled through a digital input (DIF.2706). To send the command, it is necessary to write in sequence (within 5 seconds):
 - HOLDING REGISTER 101: write the password configured with the parameter P.0004.
 - HOLDING REGISTER 102: write the value:
 - “12” to require **TEST** mode (without connecting the loads to the generator).
 - “14” to require **TEST** mode (connecting the loads to the generator).
 - “21” to go back to **AUTO**. mode.

- When a digital input, properly set with code 2031 “Test mode request” is activated, the controller shifts to **TEST** and returns to **AUTO** when the same input is deactivated.

To active the **REMOTE START** mode, the board must be in **AUTO** or in **TEST**. mode. It is possible to shift to **REMOTE START** in these cases:

- Configuring a digital input of the controller to acquire the “Remote start request” with code DIF.2032. If input is active, the controller passes to **REMOTE START** mode, if it deactivates, it returns to **AUTO**.
- Using parameters P.0426, P.0427 and P.0428, it is possible to define on a weekly basis hourly operation interval when the genset shifts automatically to **REMOTE START**. In particular, parameter P.0426 allows to set the weekdays in which this function is active and the remaining two allow you to set an hour range valid for all selected days. The range start time (P.0427) refers to the days set in P.0426, while the range end time (P.0428) refers to the same day, if its value is higher than P.0427, or to the following day if lower (across midnight). Moreover, setting P.0427 and P.0428 to the same value, you define a full day range.
- From a PC connected with a USB port (with protocol Modbus RTU). The controller shifts to **REMOTE START** after receiving the command from the serial port; it then reverts to **AUTO** when receiving the opposite command (it remains in **REMOTE START** mode in case the serial connection is interrupted before receiving the opposite command). Parameters can be password protected (P.0004, refer to par. 8.5.1) which has to be sent before every command. To send the command, it is necessary to write in sequence (within 5 seconds):
 - HOLDING REGISTER 101: write the password configured with the parameter P.0004.
 - HOLDING REGISTER 102: write the value:
 - “13” to require **REMOTE START** mode.
 - “21” to go back to **AUTO**. mode.

9.1.1 Recording of mode in event archive

The controller records any change of the operating mode in the events log, if it is enabled with bit 0 of the P.0441 parameter:

- EVT.1001: records the shift to **OFF/RESET** mode.
- EVT.1002: records the shift to **MAN** mode.
- EVT.1003: records the shift to **AUTO** mode.
- EVT.1004: records the shift to **TEST** mode.
- EVT.1005: records the shift to **REMOTE START** mode.

There are some features available for configuring the digital outputs related to the operating mode:

- DOF.3001 - “Off/reset”. The controller activates this output when in **OFF/RESET**. mode.
- DOF.3002 - “Man”. The controller activates this output when in **MAN** mode.
- DOF.3003 - “Auto”. The controller activates this output when in **AUTO** mode.
- DOF.3004 - “Test”. The controller activates this output when in **TEST** mode.

- DOF.3005 - “Remote Start”. The controller activates this output when in **REMOTE START** mode.
- DOF.3011 - “Not in OFF/RESET”. The controller activates this output when it is in AUTO or **AUTO** o **MAN** mode.
- DOF.3012 - “One of the automatic modes”. The output is activated when the controller is in one of the automatic operation modes, which is **AUTO**, **TEST** or **REMOTE START**.

9.1.2 Operation modes and logics AND/OR

The controller makes available its own operation mode for the AND/OR logics by means of the following internal statuses:

- ST.000 - “OFF/RESET”.
- ST.001 - “Manual”.
- ST.002 - “Automatic”.
- ST.003 - “Test”.
- ST.004 - “Remote Start”.

9.2 Mains



ATTENTION! The device manages the mains voltage only for Auto Mains Failure applications (P.0802 =1, see par. 5.6.1). In fact, every digital input can have an AND/OR logic associated, which determines its status. What indicated in this paragraph does not apply to Auto Start applications (P.0802 =0).

The device acquires the system’s mains voltage (single-phase or three-phase) to the purpose of commanding automatic start-ups and arrests of the engine in case of anomaly on the mains (for Auto Mains Failure applications). In emergency systems, the controller board starts the generator (and changes-over the loads to it) when the mains is out of tolerance; it changes-over the loads to the mains and stops the genset when the mains returns in tolerance.

The status of the mains can be acquired in various ways:

- **From its internal sensor** by means of the terminals **T.22...T28** (see par.5.9 and 9.2.1). In order for the device to use the measures of the mains voltages and frequency, the operator has to set the mains rated voltage through parameter P.0116.
- **By means of the digital input configured with the feature “DIF.3101 – External mains sensor”**. When said input is active, the mains is considered in tolerance; when it is not active, the main is considered out of tolerance.



INFORMATION! if the digital input is active, the mains is considered in tolerance, even if the measure of the JH sensor is enabled and if said measure indicates that the mains is out of tolerance.

9.2.1 Internal sensor

In the event the sensor can be used to acquire the mains measures, there are various parameters that influence its management:

- P.0105: rated generator frequency. Also used as mains rated frequency. All frequency-related thresholds are expressed in percentage respect to this parameter.
- P.0119: set it to 3 if mains is three-phases and 1 if single-phase.
- P.0116: nominal voltage. Its value must be the nominal phase-to-phase voltage for three-phase systems and phase-to-neutral voltage for single-phase systems. Thresholds are expressed as a percentage of it. If set to zero, mains voltage is

considered still not present, even if physically connected (it is anyway measured and displayed).

- P.0201: hysteresis applied to all the thresholds related to mains voltage and frequency. It is a percentage value related to P.0116 and to P.0105.
- P.0203: low mains voltages threshold (percentage respect to P.0116); under this value mains is considered anomalous.
- P.0204: high mains voltages threshold (percentage respect to P.0116); over this value mains is considered anomalous.
- P.0205: mains live delay. It is the time that the device waits after the mains voltage and frequency values are back to the respective bands, due to a mains anomaly before considering the mains presence.
- P.0206: mains live delay. It is the time that the device waits before considering the mains as absent due to anomalies in the measures of voltage and frequency.
- P.0236: low mains frequency threshold (percentage respect to P.0105); under this value mains is considered anomalous.
- P.0237: high mains frequency threshold (percentage respect to P.0105); over this value mains is considered anomalous.
- P.0238: mains voltages asymmetry threshold (percentage of P.0116); (over this value, mains is considered anomalous). Used in three-phase system only.
- P.0239: Rotation direction required for mains voltage. Used in three-phase system only.

In order to assess the mains status, the controller can perform up to four different checks that can be individually disabled. They are described individually below (also with examples): remember that disabling both voltages and frequency checks is not possible (in this case, mains is always considered not present).

9.2.1.1 Mains frequency control

To disable this check, one of the following conditions shall be true:

- P.0236 = 0 %.
- P.0237 = 200 %.
- P.0236 >= P.0237

Let us see a practical example upon how thresholds work, with default values for the parameters we have seen.

Parameter	Description	Default value	Frequency (Hz)
P.0105	Rated frequency	50 Hz	50.00
P.0236	Minimum frequency threshold	90.0 %	45.00
P.0237	Maximum frequency threshold	110.0 %	55.00
P.0201	Maximum hysteresis	2.5 %	1.25

The hysteresis on the various thresholds is calculated as half the difference between P.0237 and P.0236. However, it is limited by the maximum value set with parameter P.0201. The hysteresis applies to:

- Upwards, to the minimum frequency threshold (i.e., between 45.00 and 46.25 Hz).
- Downwards to the maximum frequency threshold (i.e., between 53.75 Hz and 55.00 Hz).

These values define the following bands:

0.00	V _____	
		Band A: low
45.00	V _____	
		Band B: hysteresis
46.25 (45.00 + 1.25)	V _____	
		Band C: in tolerance
53.75 (55.00 + 1.25)	V _____	
		Band D: hysteresis
55.00	V _____	
		Band G: high
xxx	V _____	

If the frequency is within the bands “B” or “D”, previous status is maintained (hysteresis). For example, in case the voltage was within the “C” band and is now within the “D” band, it is anyway considered “In tolerance”. On the other hand, in case the frequency was within the “C” band, and now is within “D” band, it is considered “Low”.

9.2.1.2 Mains voltages control

To disable this check, one of the following conditions shall be true:

- P.0203 = 0 %.
- P.0204 = 200 %.
- P.0203 >= P.0204

Let us see a practical example upon how thresholds work, with default values for the parameters we have seen.

Parameter	Description	Default value	Voltage (Volt)
P.0116	Rated voltage	400 V	400
-	Mains presence threshold	20.0 %	80
P.0203	Minimum voltage threshold	80.0 %	320
P.0204	Maximum voltage threshold	110.0 %	440
P.0201	Maximum hysteresis	2.5 %	10

The hysteresis on the various thresholds is calculated as half the difference between P.0204 and P.0203. However, it is limited by the maximum value set with parameter P.0201. The hysteresis applies to:

- Downwards, to mains availability threshold (i.e., between 70 V and 80 V).
- Upwards, to the minimum voltage threshold (i.e., between 320 V and 330 V).
- Downwards to the maximum voltage threshold (i.e., between 430 V and 440 V).

These values define the following bands:

0	V _____	
		Band A: absent
70 (80-10)	V _____	
		Band B: hysteresis
80	V _____	
		Band C: low
320	V _____	
		Band D: hysteresis
330 (320+10)	V _____	
		Band E: in tolerance
430 (440-10)	V _____	
		Band F: hysteresis
440	V _____	
		Band G: high

xxx V_____.

If the voltage is in the “B”, “D” or “F” bands, previous status is maintained (hysteresis). For example, if the voltage was in the “E” band and now it is in “D” band, it is considered however “In tolerance”. On the other hand, if it was in “C” band and now is in “D” band, it is considered “Low”.

Such statuses are managed for each phase.

9.2.1.3 Mains voltage asymmetry control

In three-phase systems, the mains can be 'out of tolerance' in case the absolute value of the three phase-to-phase voltages differs more than the set threshold.

To disable this check, simply set parameter P.0238 to zero.

Here follows an example about the various threshold used, including default values for a.m. parameters:

Parameter	Description	Default value	Voltage (Volt)
P.0116	Rated voltage	400 V	400
P.0238	Mains asymmetry threshold	10.0 %	40

In case the absolute value of two phase-to-phase voltages differs more than 40 V, the mains is seen as out of tolerance. In case the absolute values of all phase-to-phase voltages are lower than 40 V, the mains is seen in tolerance. No hysteresis is managed for this check.

9.2.1.4 Rotation direction check

For three-phases systems, mains can be 'out of tolerance' in case the rotation direction of the phases differs from the specification set with parameter P.0239 “Phase’s sequence required on mains”. To disable this check, simply set parameter P.0239 to zero.

In case a “clockwise” rotation direction is required, please set “1” in P.0239; in case the rotation direction is “counter-clockwise”, the mains is seen as “Out of tolerance”.

In case a “clockwise” rotation direction is required, please set “2” in P.0239; in case the rotation direction is “counter-clockwise”, the mains is seen as “Out of tolerance”.

9.2.1.5 Internal mains sensor status

In order to diagnose the mains “global” status, the following algorithms are used, shown in their computing order:

- In case the status of all existing voltages (1 or 3) **and** the frequency are “Absent”, also the global status is “Absent”.
- In case the status of all existing voltages (1 or 3) **and** the frequency is “In tolerance”, also the global status is “In tolerance”.
- In case the status of at least one voltage **or** the frequency is “High”, also the global status is “High”.
- In case none of the previous conditions occurs, global status is “Low”.

In case the tests show that the mains is “In tolerance”, perform also the following tests:

- If we have an unusually high asymmetry on the voltages, the global status is “Low”.
- If the direction of rotation of the mains is different from the one configured, the global status is “Low”.

9.2.2 External mains sensor.

The use of a digital input is provided, configured with the function DIF.3101 - “Sensor of external mains”, for the connection with a generic mains sensor in alternative, or in addition to the internal sensor. **To use the external sensor and deactivate the internal one, it is necessary to put the rated mains voltage P.0116 to zero.**

i INFORMATION! Even with the internal sensor deactivated (that is, with P.0116=0) the device performs and shows the mains measures, even if it doesn't use them to define its status.

The status of the mains is considered:

- “Absent” if the input is no active.
- “In tolerance” if the input is active.

if the input is active, the mains is considered in tolerance, even if the measure from the internal sensor is enabled and such measure indicates that the mains is out of tolerance.

It is valid what written in the next paragraph, as per the internal sensor.

9.2.3 Mains global status

Whichever the method used to acquire the mains instant status, to the extent of the application operation logics, the mains global status is described in four steps:

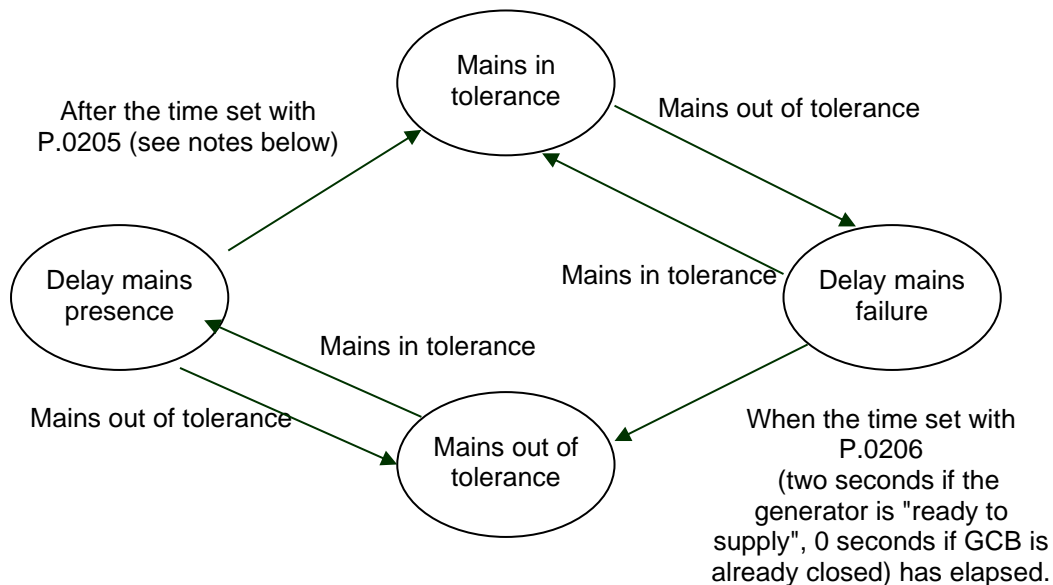

The use of the “mains presence delay” (configured with parameter P.0205) depends on the presence of one or more generators supplying the loads, and on the configuration of parameter P.0250. It is a bit-managed parameter. At the moment two bits are defined:

- Bit 0: used when the controller is in OFF/RESET mode. In this mode, the controller does not normally manage the “mains presence delay” (to re-power the loads as soon as possible, since they are not powered by the generators). By setting bit 0 of P.0250 to “1”, the controller manages the “mains presence delay”.
- Bit 1: used when the controller is in AUTO mode. In this mode, the duration of the “mains presence delay” depends on the presence of generators supplying the loads, and on the value of this bit:
 - At least one generator supplying the loads: the duration of the “mains presence delay” is set by parameter P.0205.

- No generator supplying the loads and bit 1 of P.0250 is “1”: the duration of the “mains presence delay” is set by parameter P.0205.
- No generator supplying the loads and bit 1 of P.0250 is “0”: the duration of the “mains presence delay” is 0 seconds.

9.2.4 Communication and events

The controller records any change of the mains status in the events log, if it is enabled with bit 1 of the P.0441 parameter:

- EVT.1010: Lack of mains voltage.
- EVT.1011: Mains voltage present, but “out of tolerance”.
- EVT.1012: Network voltage present and “in tolerance”.

The following feature for the configuration of the digital outputs related to the mains status is also available:

- DOF.3033 - “Mains within tolerance”. The controller activates this output when the mains voltages and frequency are in tolerance from the time configured.

In addition, the controller makes available the mains statuses for the AND/OR logics by means of the following internal statuses:

- ST.016 - “Mains voltage/frequency present”
- ST.017 - “Mains out of tolerance or absent”
- ST.018 - “Delay for mains within tolerance”
- ST.019 - “Mains within tolerance”.
- ST.020 - “Delay for mains out of tolerance or absent”

9.3 Generator

The controller acquires generator (single or three-phase) voltage and frequency in order to protect the loads and the generator itself from operating outside its tolerance thresholds. To connect the generator to the controller, see par. 5.10.

By setting P.0802 to “11-DRIVE”, it is possible to work with the engine only, without the generator. To work in this way, you need to:

- Set P.0802 to “11-DRIVE”.
- Make sure that board is able to acquire the engine speed (from Can Bus communication). **This point is fundamental, because the controller has no other way to verify the under-speed and over-speed conditions.**
- Set parameters P.0305, P.0306, P.0307 and P.0308 correctly. They normally configure the minimum and maximum frequency protections: when working without the generator they are used for speed protection (the percentage values are calculated with respect to the rated engine speed).
- Set parameters P.0331 and P.0332 correctly (over-speed protection).

Once this is done, the controller works in this way:

- It hides all M.XX pages except M.01.
- On page M.01 the generator symbol is replaced with the engine symbol, the circuit breaker with the clutch symbol and the power measurements are replaced by the engine speed (rpm). The power measurements on the loads are also hidden.
- The “operating conditions failure” situation is evaluated only on the engine speed, even in MAN mode.
- Generator related events are not logged.
- The following alarms are not managed:
 - 01 – minimum voltage.

- 02 - maximum voltage
 - 03 - minimum frequency.
 - 04 - maximum frequency.
 - 06 - maximum current.
 - 16 - short circuit.
 - 49 - maximum active power.
 - 52 – voltage unbalance.
 - 53 - current unbalance.
 - 55 - wrong phases sequence.
 - 56 - low voltage.
 - 58 - low frequency.
 - 59 - high voltage.
 - 60 - high frequency.
- The anomaly "A099 - Minimum engine speed" is now managed. After the engine has reached the rated speed at start-up (between the thresholds P.0305 and P.0307), if it falls below the threshold P.0305 for P.0306 seconds, the controller activates the anomaly. It is an alarm: it forces the immediate opening of the GCB, and stops the engine without the cooling cycle. **Note: in this case the thresholds P.0305 and P.0307 are to be considered as percentages of the rated speed.** For this reason, if you program them from the controller, the last display line shows the equivalent value both in Hz and in rpm.

9.3.1 Genset frequency

Several parameters are related to frequency measure of the generator:

- P.0105: rated generator frequency. All frequency measure related thresholds are expressed percentage of it.
- P.0228: threshold (percentage of P.0105) under which the engine is considered idle.
- P.0229: threshold (percentage of P.0105) above which the generator is considered started.
- P.0305: low voltage threshold (percentage related to P.0105) below this value the generator cannot be connected to the loads.
- P.0307: high voltage threshold (percentage related to P.0105) above this value the generator cannot be connected to the loads.
- P.0202: hysteresis applied to all the thresholds related to generator frequency. It is a percentage value of P.0105.

Let us see a practical example upon how thresholds work, with default values for the parameters we have seen.

Parameter	Description	Default value	Frequency (Hz)
P.0105	Rated frequency	50 Hz	50
P.0228	Stopped engine threshold due to frequency	10.0 %	5
P.0229	Started engine threshold due to frequency	20.0 %	10
P.0305	Minimum frequency threshold	90.0 %	45
P.0307	Maximum frequency threshold	110.0 %	55
P.0202	Hysteresis	2.5 %	1.25

To the two settable thresholds (P.0305 and P.0307) the hysteresis is entirely applied in the threshold input direction. This means that the frequency is out of tolerance if out of thresholds P.0305 and P.0307. It is in tolerance if within the thresholds P.0305+hysteresis and P.0305-hysteresis, otherwise it maintains the previous status.

0	Hz	Band A: absent
5	Hz	Band B: Hysteresis
10	Hz	Band C: minimum
45	Hz	D band: Hysteresis
46.25	Hz	Band E: in tolerance
53.75	Hz	Band F: Hysteresis
55	Hz	Band G: maximum
xxx	Hz	

If the frequency is in “B”, “D”, “F” bands, it maintains the status it had before (hysteresis). For example, if the frequency was in “E” band, and now is in “D” band, it is still considered in tolerance. On the other hand, if it was in “C” band and now is in “D” band, it is considered “Low”.

Thresholds P.0305 and P.0307 are used also to manage the generator/engine protections on frequency. These protections can be individually disabled setting to zero the relevant parameter that specifies the delay (respectively P.0306 and P.0308). Even if the protections are disabled, thresholds are however used in order to define the frequency status: this allows not to switch the loads on the generator if the electrical magnitudes are out of the tolerance band.

9.3.2 Genset voltages

Several parameters are related to voltage measures of the generator:

- P.0101: indicates if it is a three-phase generator (3) or a single-phase generator (1).
- P.0102: rated generator voltage. Its value must be the nominal phase-to-phase voltage for three-phase systems and phase-to-neutral voltage for single-phase systems. Thresholds are expressed as a percentage of it.
- P.0202: hysteresis applied to all the thresholds related to generator voltage. It is a percentage value of P.0102.
- P.0226: threshold (percentage of P.0102) under which the engine is considered stopped.
- P.0227: threshold (percentage of P.0102) over which the engine is considered started.
- P.0301: low generator voltage threshold (percentage of P.0102); under this value the generator cannot be connected to the loads.
- P.0303: high generator voltage threshold (percentage of P.0102); over this value the generator cannot be connected to the loads.

Let us see a practical example upon how thresholds work, with default values for the parameters we have seen.

Parameter	Description	Default value	Voltage (Volt)
P.0102	Rated voltage	400 V	400
P.0226	Stopped engine threshold due to voltage	17.5 %	70
P.0227	Started engine threshold due to voltage	20.0 %	80
P.0301	Minimum voltage threshold	75.0 %	300
P.0303	Maximum voltage threshold	112.5 %	450
P.0202	Hysteresis	2.5 %	10

To the two settable thresholds (P.0301 and P.0303) the hysteresis is entirely applied in the threshold input direction. This means that generator voltage is out of the tolerance if out of the thresholds P.0301 and P.0303; it is in tolerance if between P.0301 + hysteresis and P.0303 – hysteresis; otherwise, the previous status is maintained.

Keeping in account these values, the following bands are defined:

0	V	_____
		Band A: Absent
70	V	_____
		Band B: Hysteresis
80	V	_____
		Band C: Low
300	V	_____
		D band: Hysteresis
310 (300+10)	V	_____
		Band E: In tolerance
440 (450-10)	V	_____
		Band F: Hysteresis
450	V	_____
		Band G: High
xxx	V	_____

If the voltage is in the “B”, “D” or “F” bands, previous status is maintained (hysteresis). For example, if the voltage was in the “E” band and now it is in “D” band, it is considered however “In tolerance”. On the other hand, if it was in “C” band and now is in “D” band, it is considered “Low”.

Such statuses are managed for each phase. With a three-phase system, in order to diagnose the generator “global” status, the following algorithms are used, shown in the order they are computed:

- In case all the three phases are in “Absent” status, global status is also “Absent”.
- In case all the three phases are in “In tolerance” status, global status is also “In tolerance”.
- In case at least one phase is in “High” status, global status is also “High”.
- In case none of the previous conditions occurs, global status is “Low”.

Thresholds P.0301 and P.0303 are used also to manage the generator protections on voltage. These protections can be individually disabled setting to zero the relevant parameter that specifies the delay (respectively P.0302 and P.0304). Thresholds are however used in order to define voltage status: this allows not to switch the loads on the generator if the electrical magnitudes are out of the tolerance band, even though protections are disabled.

9.3.3 Generator status.

For general management purposes, generator can be in three conditions:

- Steady out of tolerance: the generator voltages **and/or** frequency status must be continuously other than “In tolerance” for two seconds.
- Steady within tolerance: generator's voltage **and** frequency global status must be “within tolerance” for at least 0.5 seconds.
- Transient: shifting from status “a” to status “b” or vice versa.

9.3.4 Communication and events

The controller records any change of the generator's status in the events log, if it is enabled with bit 2 of the P.0441 parameter:

- EVT.1020: Lack of voltage on the generator.
- EVT.1021: Generator voltage present, but “out of tolerance”.

- EVT.1022: Generator voltage present and “within tolerance”.

The following feature for the configuration of the digital outputs related to the generator status is also available:

- DOF.3032 - “Generator in thresholds”. The controller activates this output when the generator voltages and frequency are within tolerance from the time configured.

In addition, the controller makes available the generator statuses for the AND/OR logics by means of the following internal statuses:

- ST.024 - "Generator voltage/frequency present"
- ST.025 - "Generator out of tolerance or absent"
- ST.026 - "Delay for generator within tolerance"
- ST.027 - "Generator within tolerance"
- ST.028 - "Delay for generator out of tolerance or absent"

9.4 Automatic intervention of the generator inhibited.

In AUTO mode, whatever the kind of application and the Mains status, two causes can anyway inhibit the genset automatic start:

- In predefined time intervals.
- Digital input.

When there is an inhibition active, a flashing lock  is displayed in the top right corner of the display.

 **INFORMATION!** The inhibition status does not affect TEST and REMOTE START modes.

9.4.1 Inhibition from contact

The controller can use a digital input programmed for inhibiting the genset automatic operation (function 2501 - genset operation inhibit). In case of an “active” input, the engine is never automatically started, not even if the application’s condition require.

Use parameter P.0207 to set a delay between input's physical activation and this function's logic activation: the delay can only be applied if the controller is in AUTO mode, otherwise the delay is null.

Use parameter P.0208 to set a delay between input's physical de-activation and this function's logic de-activation: in case the generator is already running, the delay is two seconds (firm).

When a function with value 2501 is coupled with a digital input, acquisition of this input depends on the time set in P.0207 and/or P.0208; the acquisition time related to the digital input is skipped.

The controller also makes available, to the use of AND/OR logics, the internal status ST.080 - "Contact starting inhibition".

The controller records any change of the inhibition status in the events log, if it is enabled with bit 6 of the P.0441 parameter:

- EVT.1013: Inhibition activated (from configurable input)
- EVT.1014: Inhibition not activated (from configurable input)

9.4.2 Inhibition from clock

Using parameters P.0421, P.0422 and P.0423 it is possible to define on a weekly basis the hourly operation range. In particular, parameter P.0421 allows to set the generator's weekly operation days. The remaining two allow to set an hour range valid for all selected days. The range start time (P.0422) refers to the days set in P.0421, while the range end time (P.0423) refers to the same day, if its value is higher than P.0422, or to the following day if lower (across midnight). Moreover, setting P.0422 and P.0423 to the same value, you define a full day range.

Apart from the days and time configured, the inhibition to the automatic intervention is active.

The controller also makes available, to the use of AND/OR logics, the internal status ST.081 - "Clock/calendar starting inhibition".

9.5 Engine

The device can start, stop and protect the engine by means of a series of thresholds on the acquired measures (oil pressure, coolant temperature, speed etc.). Before describing engine management sequences, it is necessary to define in which way the controller determines the engine running status.

9.5.1 Engine running/stopped status acknowledgement

There are three engine statuses:

- **Idle:** the activation of the command is allowed for starter motor.
- **In movement:** the engine is not considered running, therefore:
 - If the command for the starter motor is active, it is maintained to try to get the engine started.
 - If the command for the starter motor is not active, the controller impedes the starting (as the engine is rotating).
- **Running:** the controller deactivates the command of the starter motor and impede its restart.

The controller recognises the status of the engine **considering** the following conditions:

- **From the signal voltage D+ of the alternator** This control is enabled if the measure of the D+ voltage is enabled (P.4041 must be set as AIF.1300 – "D+ signal").

Two thresholds are available (P.0230 e P.0231), which have to be both different from zero and P.0231 has to be major than P.0230 (otherwise this check is disabled).

The instantaneous status of the engine is:

- **Idle** if the D+ voltage is lower than P.0230.
- **In movement** if the D+ voltage is higher than P.0230, but lower than P.0231.
- **Running** if the D+ voltage is higher than P. 0231.
- **From low and/or minimum oil pressure contacts.** This control is enabled if parameter P.0232 is different from zero and if digital inputs are configured to acquire the status of the oil pressure switches (DIF.4221 and/or DIF.4222). The instantaneous status of the engine is:
 - **Idle** if all inputs are active (with engine stopped, in effect, the oil pressure gets lower and these contacts are supposed to activated).
 - **In movement** if at least one input is not active.

- From generator voltage. Two thresholds are available (P.0226 e P.0227), which have to be both different from zero and P.0227 has to be major than P.0226 (otherwise this check is disabled).

The instantaneous status of the engine is:

- **Idle** if the voltages measured on all generator phases are lower than P.0226.
 - **In movement** if the voltage measured on at least one generator phase is higher than P.0226, but all are lower than P.0227.
 - **Running** if the voltage measured on at least one generator phase is higher than P. 0227.
- From generator frequency. Two thresholds are available (P.0228 e P.0229), which have to be both different from zero and P.0229 has to be major than P.0228 (otherwise this check is disabled).

The instantaneous status of the engine is:

- **Idle** if the generator frequency is lower than P.0228.
 - **In movement** if the generator frequency is higher than P.0228, but lower than P.0229.
 - **Running** if the generator frequency is higher than P. 0229.
- From CAN-BUS (ECU Interface): if the engine signals the status of started on CAN-BUS. This control is not used if the CAN-BUS connection is disabled (parameter P.0700 "Engine type" set to 0).

The engine is generally considered:

- **Stopped** if all previous checks (all those not enabled) show the "idle" status consecutively for **five seconds**.
- **In movement**, if at least one of the previous checks show "in movement" or "running".
- **Running**, if at least one of the previous checks show "running" consecutively for **at least 0,2 seconds**.

9.5.2 Engine commands

The controller can handle the following different commands for engine management:

- **START**: command for the starter.
- **FUEL**: command for the fuel solenoid valve.
- **STOP**: stop command when energized.
- **PREHEAT**: command for Diesel engines glow-plugs preheating.

All digital outputs of the controller are configurable and therefore the engine commands can be associated in any way to the outputs of the controller. The outputs START and FUEL are assigned in default to outputs **T.03** and **T.04**, which are able to supply a major current, but it is possible to reassign them when needed (see par. 5.4).

The command **STOP** is assigned in default to output **T.05** (but it can be reassigned itself). For the other four commands, being optional, no dedicated outputs are provided.

To associate each of these commands to any of the controller's outputs, parameter P.3001 must be used (for output 1 or on the equivalent parameters for the other outputs) (menu 1 system, 1.7 digital Inputs/Outputs, 1.7.3 digital Outputs, 1.7.3.1 digital Outputs) using values:

- **DOF.1001**: glow-plugs preheating (PREHEAT).

- **DOF.1003:** fuel valve (FUEL).
- **DOF.1005:** start command (START).
- **DOF.1006:** stop command when energized (STOP).

9.5.3 Command sequence of the engine

9.5.3.1 Starting

The start-up sequence is activated if there are no failures, downloading and deactivations, and if at least one of these conditions happens:

- **In MAN mode:**
 - If button **START** is pressed. If the “Protected starting” function is active (bit 2 of P.0495 =1), if you press the button just once, you select mode **MAN** and it is necessary to press it again to start the engine. Furthermore, there are two possible sequences of manual start-up:
 - If bit 1 of parameter P.0495 (“Keyboard options”) is to zero, by keeping button **START** pressed, the start-up begins; the duration is set by the operator: the attempt interrupts when the operator releases button **START**.
 - Automatic sequence: pressing and releasing button **START**, the device starts the engine automatically; the maximum duration of the starting attempt is selected through parameter P.0210.
 - If Modbus commands via USB port are used (**in this case, the automatic sequence is used.**). The commands can be password protected (P.0004) which has to be sent before any command. To send the command, it is necessary to write in sequence (within 5 seconds):
 - HOLDING REGISTER 101: write the password configured with the parameter P.0004.
 - HOLDING REGISTER 102: write value “11”.

In **MAN** only one attempt of start is done (even if the automatic sequence is performed), without activating the “failed start” anomaly.

- **In AUTO mode:**
 - If the **TEST** mode is activated (see par.). 9.1).
 - If the **REMOTE START** mode is activated (see par.). 9.1).
 - If an automatic starting is required and no inhibition to the starting is activated (see 9.4).

In **AUTO** mode, the device automatically starts the engine and possibly with more than one attempt; the maximum duration of the single starting attempt is selected with parameter P.0210, the number of attempts with parameter P.0211.

The stand-by statuses are those of **stop** and **no stop** (see par. 9.5.1). The controller deactivated all commands to engine for both. The status of **no stop** means, therefore that the engine has been started by others or that for any reasons, e.g. A failure on the fuel interception valve, didn't stop after a stopping cycle. From the controller point of view the two statuses are different, since the engine protections are never activated as the controller considers that there is another device that has started and is being checking the engine.

From stand-by statuses, when a starting cycle is required (manual or automatic sequence), if the engine was **not stop**, the engine control unit is not commanded and we pass to the **running status** (in **MAN**) or that of **start-up confirmation** (in **AUTO**). If the engine was idle, instead, the sequence proceed with the cycle of **pre heating** of the engine.

The **pre-heating** cycle is performed if parameter P.0209 is set (“pre-heating cycle duration) different from zero. In this status the **FUEL** and **PREHEAT**. It is not obligatory to configure an

input as pre-heating command; this allows to use it even without pre-heating in order to add a delay between commands **FUEL** and **START**.

If the **preheating** cycle is not performed, the controller manages an intermediate status of 0,2 seconds duration, where commands **FUEL** and **PREHEAT** are active. This status is necessary to guarantee a minimum delay between the opening of the fuel electro-valve and the activation of the engine control unit. This because some electro-valves can get stuck if there is already fuel flow during the opening.

From the preceding statuses, it is possible to move forward with the **start** of the engine.

During the **start**, commands **FUEL**, **PREHEAT** and **START** are activated. If, instead, the starting cycle ends (see previous notes about the starting sequence in manual mode) without diagnosing the started engine status, the sequence proceed with:

- The **starting check** status, if we are in **MAN**. Actually, the given command could be enough for the engine, which therefore could get started. In this state the engine has to be checked for a maximum time of 10 seconds to check if it starts. It is only active the command **FUEL** to favour the possible starting. If the engine does not get started at the end of the 10 seconds, it returns to status **idle**.
- The status **of delay between the two starts** if we are in **AUTO**, **TEST** or **REMOTE START**. The duration of this status is configured with parameter P.0212 (“Delay between two starts”). At the end we proceed towards the **washing** status. This status is performed for a number of times configured with parameter P.0211 (“Number of starting attempts”): if after all configured attempts the engine does not activate, the controller activates the failure AL.022 (“A022 failed starting”) and proceed with the **stop** status. In this status, commands **PRE-HEATING** and **FUEL** (if requested) are active, so to use this status for the pre-heating of the Diesel engine spark plugs.

If the controller recognises the engine running status, the sequence goes on with the status of:

- **Running** if we are in **MAN**.
- **Starting confirmation** if we are **AUTO**, **TEST** or **REMOTE START**. If the selected application in P.0802 is “11-DRIVE”, this status is used in **MAN** mode also. This status is necessary to wait that the genset reaches the full speed. The engine could, in effect, turn off (the controller could have diagnosed it only because it is the engine control unit which lets it move). In these cases, the controller has to attempt to start it again, up to the end of the configured attempts. From this status we proceed towards **running** if the genset reaches the full speed (in this case the starting is real and an eventual turning off is symptom of big anomalies on the genset); if the engine stops, we proceed towards the **delay between two attempts** ; towards the **stop** status if the engine does not stop, but the genset does not reach the full speed within the time configured with parameter P.0217 (“Maximum time for full speed conditions”): the controller activates the failure AL.008 (“A008 – Failed full speed conditions”). In this status only command **FUEL** is active.

In this status only command **RUNNING** is active.

9.5.3.2 Stop

The engine can be stopped in two ways:

- a) **With standard procedure**. Such procedure consists in performing an engine cooling cycle (only if the load has previously been switched to the genset), keeping it running without load. This procedure only applies in **AUTO** if:
 - There are no more automatic starting requests (see above)

- An anomaly, qualified as “deactivation” or “discharge” occurred (it is an anomaly typically dangerous for loads but not for the engine).
- b) **With an emergency procedure.** This procedure requires immediate engine stop, without engine cooling cycle. It applies if:
 - The controller is forced in **OFF_RESET**.
 - If the stop is requested in **MAN**.
 - Any anomaly classified as “failure” is activated and if the engine is in a different status from stop or **no stop**.

The stop sequence is performed in the following cases:

- When a failure, download or deactivation happen.
- Using the commands received from USB port. The commands can be password protected (P.0004) which has to be sent before any command. To send the command, it is necessary to write in sequence (within 5 seconds):
 - HOLDING REGISTER 101: write the password configured with the parameter P.0004.
 - HOLDING REGISTER 102: write value “21” (standard stop) or “22” (emergency stop).
- In **MAN**:
 - Pressing “STOP” from the controller panel.
- In **AUTO**:
 - When the automatic intervention of the genset is no more requested.

 **INFORMATION!** normally if you press the digit **STOP** in **AUTO** mode, the controller activates the failure A007 (“manual stop in automatic”): the engine is therefore stopped with emergency procedure. It is possible to disable the digit **STOP** in **AUTO** mode acting on bit 0 of parameter P.0495 (keyboard options).

The stop phase can be also performed when the engine is already stopped.

9.5.3.2.1 Stop with standard procedure.

The stop standard procedure consists in performing a **cooling** cycle for the engine first (during which the controller disconnects the genset from the loads). Such cycle is performed only if during the **running** status the loads have been connected to the generator. During this cycle, only **FUEL** command is active. The duration of the cycle is configurable with parameter P.0215 (“Duration of cooling cycle”). It is also possible to configure parameter P.0271 with a threshold of temperature below which the cooling cycle ends and the engine is stopped. In any case, the maximum duration of the cooling cycle is given by parameter P.0215.

From the **cooling** status it is possible to go back to the in **running** status if the stop requests cease and there is at least one starting request (for example, we were in this status following to the back from mains, but during this status the mains fails again). The cycle can be interrupted also if there is an emergency stop request (a failure or the controller in **OFF_RESET**). In this case, or at the end of time P.0215, we proceed with the emergency stop cycle.

9.5.3.2.2 Stop with emergency procedure.

The emergency stop procedure consists in stopping the engine without performing the cooling cycle. Such procedure is also common to the normal stop, after, thus, the cooling cycle.

During the **stop** phase, the **START** and **PREHEAT** commands are removed and it the **STOP** command is activated instead.

The **FUEL** command is removed after the configured time with parameter P.0234 (“Delay between commands STOP and FUEL”). This delay is useful, when the command is given through other methods (e.g., via CANBUS) to avoid that the engine in stopping phase causes a depression in the fuel ducts, which might get the electro-valve stuck at the next opening command; it is also useful on electronic engines to supply the control unit through the output **FUEL** in the way that the control unit itself remains supplied during the stopping. The duration of this phase is configurable with parameter P.0213 (“duration of stop pulse in excitement”. At the end, we pass to the stop waiting phase. If during this phase all the stop requests cease and there is at least one starting request, we pass to the **stop cancellation one and only** if the engine has been diagnosed stopped.

It is not possible to interrupt an automatic stop cycle as situations can be happen where it is difficult to restart the engine if it was not completely stopped.

During the **stop waiting** stop waiting phase all engine commands deactivate and therefore the stop of the engine is waited. The duration of such waiting is configurable with parameter P.0214 (“Duration of stopping cycle”), from which the configured time with P.0213 is subtracted (“Duration of stopping command”). At the end of this phase, if the engine has not stopped, the failure A021 is activated (“A021 – failed stop”) and we pass to the status of **no stop**. The whole phase of **stop waiting** (and then also the failure A021) can be disabled anyway by setting zero in parameter P.0214. If the engine stops, it goes back to the **stop** status. This phase cannot be interrupted to perform further starting.

The **cancel stop** phase is only necessary to allow a short delay between the deactivation of the eventual **STOP** command and the **FUEL** activation. This delay is of 0,2 seconds, at the end of which we go back to the **stop** status, from where we will proceed immediately with the starting if there are the conditions (and restarting from zero with the counting of the starting attempts).

9.5.4 Communication and events

The controller records any change of the engine's status in the events log, if it is enabled with bit 3 of the P.0441 parameter:

- EVT.1040: Engine stopped
- EVT.1041: Starting cycle
- EVT.1042: Engine running.
- EVT.1043: Cooling cycle
- EVT.1044: Stopping cycle

The controller records any change of the start/stop requests in the events log, if it is enabled with bit 6 of the P.0441 parameter:

- EVT.1050: Manual start-up command
- EVT.1051: Manual stop command
- EVT.1052: Auto start command
- EVT.1053: Auto stop command
- EVT.1054: TEST mode requested by digital input.
- EVT.1055: Command for stop in TEST mode from digital input.
- EVT.1056: Command for start in TEST mode from serial port
- EVT.1057: Command for stop in TEST mode from serial port
- EVT.1058: TEST mode requested by clock/calendar.
- EVT.1059: Command for stop in TEST mode from clock/calendar
- EVT.1062: Starting command for failure to close MCB.

In addition, the controller makes available the requests start/stop and the engine statuses for the AND/OR logics by means of the following internal statuses:

- ST.032 - "Engine running".
- ST.033 - "Oil protections enabled"
- ST.035 - "Engine sequence: standby"
- ST.036- "Engine sequence: starting"
- ST.038 - "Engine sequence: delay before power delivery"
- ST.039 - "Engine sequence: ready for power delivery"
- ST.040- "Engine sequence: cooling"
- ST.041- "Engine sequence: arrest"
- ST.096 - "Ready for power delivery"

9.6 Circuit breakers management

9.6.1 Circuit breakers command.

Four different commands are available for the **MCB** circuit breaker management, configurable on one or more digital outputs (see par. 5.6)

- **DOF.2001** - "MCB (NC) Under voltage coil". This feature can be used to supply the minimum voltage coil (if any) of the circuit breaker. The controller enables this output when it must open the breaker, and disables it when it must close the breaker: the real closing command will be activated with at least 0.5 seconds after the disabling of this output. It is therefore necessary to use a contact which is **normally closed**, so that when the controller is not supplied, the under-voltage coil is enabled and the breaker can be closed.
- **DOF.2002** - "MCB opening coil". The controller enables this output when it wants to open the circuit breaker: the output goes back in standby once the circuit breaker feedback indicates that it is open (or when the opening time-out expires).
- **DOF.2003** - "MCB closing coil". The controller enables this output when it wants to close the circuit breaker (ensuring that the function DOF.2001 has been active for at least 0.5 seconds): the output goes back in standby once the circuit breaker indicates that it is closed (or when the closing time-out expires, or the synchronism condition no longer exists).
- **DOF.2004** - "Commands of steady MCB opening". The controller disables this output to open the circuit breaker (guaranteeing that the possible function DOF.2001 is active from at least 0.5 seconds): the output remains active even with open circuit breaker. The controller disables this output to close the circuit breaker: the output remains disabled even with the breaker closed. It is strongly recommendable to use the contact normally closed of an external relay commanded by this output, in the way that when the controller is not supplied, the MCB circuit breaker closes (see par. 5.6.1. It is anyway possible to directly command a battery voltage breaker, by inverting the polarity of the output (see par.5.6.2) Use this output with the remote-control switches, not with the motorized breakers.

Four different commands are available for the **GCB** circuit breaker management, configurable on one or more digital outputs (see par. 5.6):

- DOF.2031 - “GCB Under voltage coil”. This feature can be used to supply the minimum voltage coil (if any) of the circuit breaker. The controller disables this output when it must open the breaker, and enables it when it must close the breaker: the real closing command will be activated with at least 0.5 seconds after the enabling of this output.
- DOF.2032 - “GCB opening coil”. The controller enables this output when it wants to open the circuit breaker: the output goes back in standby once the circuit breaker feedback indicates that it is open (or when the opening time-out expires).
- DOF.2033 - “GCB closing coil”. The controller enables this output when it wants to close the circuit breaker (ensuring that the function DOF.2031 has been active for at least 0.5 seconds): the output goes back in standby once the circuit breaker indicates that it is closed (or when the closing time-out expires, or the synchronism condition no longer exists).
- DOF.2034 - “GCB steady closing command”. The controller enables this output when it wants to close the circuit breaker (ensuring that DOF.2031 has been active for at least 0.5 seconds): the output stays active even with circuit breaker closed. The controller disables this output when it must open the breaker: the output remains enabled even with the breaker open. Use this output with the remote-control switches, not with the motorized breakers.

9.6.2 Acquiring breakers status

The features of inputs DIF.3001 - “GCB breaker status” and DIF.3002 - “MCB breaker status” are used by the controller for acquiring the feedback connection input, respectively of breakers GCB and MCB. The controller uses these inputs for:

- Issuing failed opening or failed closing warnings.
- For its own operating sequence.
- It is also used to detect the status of the circuit breaker when it is commanded by external devices.
- To view the real status of the circuit breakers on page S.01.

The delay associated to the input (P.2002 for input 1 or equivalent parameter for the other inputs) is used as maximum time for opening or closing the breaker.

Theoretically, the controller could even work without this feedback. In this case, the controller considers that the breaker is closed once the closing command is issued; it considers that the breaker is open once the opening command is issued. In reality, it is always better to connect the feedback.

9.6.3 OFF/RESET management logic

In this mode, the controller always commands the GBC in opening. If MCB exists and is commanded by the controller, it is always commanded in closure.

9.6.4 Switching logic in AUTO mode

After detecting the mains failure condition, the controller starts the engine. After detecting the engine running and with parameters of generator frequency and voltage in the respective windows of supply (see par. 9.3), once the delay set in P.0218 has expired, the controller commands the load switching.

It is possible, through parameter P.0248 to define when the MCB circuit breaker must be open:

- 0 (default): MCB is only opened when the generator is ready to supply.
- 1: MCB is opened immediately after the “mains failure delay”, still before starting the engine. It is useful as protection for the loads in case the mains is not totally absent, but simply out of tolerance.

9.6.4.1 Change-over switch.

Only for Auto Mains Failure applications (single genset in emergency to the mains): the controller is able to command a switch instead of breakers. To do so, it is enough not to configure any output for MCB command. Use the “GCB Stable Close Command” (DOF.2034) to command the switch.

In addition, it is possible to configure a minimum time before which it is not possible (not in manual mode, nor in automatic) to invert the command of the switch (P.0220 “Time of maintenance switch command”). This is useful because if the command is inverted during the movement phase, with some type of power switches it is possible that they lock themselves, and a manual action will be required to unlock them.

9.6.4.2 Switching management with circuit breakers

In case the controller commands both the MCB and GCB circuit breaker, the device, if there are adequate conditions on mains and generator, opens the other breaker first and then closes the desired breaker. In this case, it is possible to configure the duration of the pause with both switches open, by means of P.0219 parameter (“contactors controls exchange time”).

9.6.5 MAN or TEST management logic

With operation in **MAN**, the switching is manually commanded through a digital input configured with function

- DIF.2041 “Request of load taken in manual”

To which a selector or a switch NO must be connected, with position of steady opening/closing. Activating and keeping the input active, the opening of MCB and the subsequent closure of GCB is commanded to supply the generator loads; deactivating the input, the opening of GCB and the closure of MCB are commanded.

Alternatively, it is also possible to connect some external buttons NO of breakers opening/closing to the digital inputs of the controller. The controller will use these inputs (only in **MAN**) exactly as:

- DIF.1001 - “GCB close command”.
- DIF.1002 - “GCB open command”.
- DIF.1031 - “MCB close command”.
- DIF.1032 - “MCB open command”.

It is possible to command the circuit breakers with only two NO buttons on the outputs configured with the two closure commands IF.1001 and DIF1031; by pressing the button, you command the closure of the responding breaker (and the opening of the other, if closed). If you press it once again, you command the opening of it (but never the closure of the other breaker). The logic of the controller impedes to have both the breakers closed.

It is possible to manage the breakers using Modbus commands via USB. To send the commands you need to write in sequence (within 5 seconds):

- HOLDING REGISTER 101: write the password configured with the parameter P.0004.
- HOLDING REGISTER 102:
 - “31” and “32” to open the GCB.
 - “33” to close the GCB.
 - “41” to open the MCB.
 - “43” to close the MCB.

In **MAN** the GCB closing command, in any way it is provided, can be activated only if all the following conditions apply:

- Generator voltages and frequency in tolerance for a proper time.
- The engine has been started by the controller (the fuel solenoid valve command must be active).
- If there are no locks or deactivations.

9.6.6 Automatic power delivery of the generator inhibited.

In all automatic operating modes of the controller, the GCB breaker can be forced open by certain causes, even if the operating logic of the system commands it's closing. Here is a description of these causes.

- It is possible to use a digital input configured with feature DIF.2502 – “Loading inhibition”. When this input is active, the controller commands the opening of the GCB (and subsequent closing of the MCB, if possible).
See also the description of EJP function on par. 11.4
- You can use a command from the serial port. Such command is temporary (only lasts 30 seconds): so, it must be continuously confirmed if you want to keep the GCB open. To send the commands you need to write in sequence (within 5 seconds):
 - HOLDING REGISTER 101: write the password configured with the parameter P.0004.
 - HOLDING REGISTER 102:
 - “31” or “32” to inhibit automatic power delivery (forces GCB open).
 - “33” to remove automatic power delivery inhibition.

9.6.7 Events and signalling related to the breakers

The controller records any change of the GCB and MCB breakers status in the events log, if enabled with bit 4 and 5 respectively, of the P.0441 parameter:

- EVT.1030: GCB close command
- EVT.1031: GCB open command
- EVT.1032: GCB closed.
- EVT.1033: GCB open.
- EVT.1035: MCB close command
- EVT.1036: MCB open command
- EVT.1037: MCB closed.
- EVT.1038: MCB open.

The board makes controls and status of the switches available, for AND/OR logics, through the following internal statuses:

- ST.064 - "GCB status"
- ST.065 - "MCB status"
- ST.068 - “GCB steady closing command”.
- ST.069 - “MCB steady closing command”.
- ST.070 - “Minimum voltage coil command for GCB”
- ST.071 - "Impulse open command for GCB”
- ST.072 - "Impulse close command for GCB”

- ST.073 - "Minimum voltage coil command for MCB"
- ST.074 - "Impulse open command for MCB"
- ST.075 - "Impulse close command for per MCB"

In addition, the controller makes available the generator automatic power delivery inhibition for the AND/OR logics by means of the following internal statuses:

- ST.088: from contact.
- ST.090: for controls from the serial port.

10 Anomalies

This chapter describes all the anomalies managed by the controller. Some of these act as protections for the loads, for the generator or for the engine. There is also signalling of specific events in the plant management. Before describing them in detail, some definitions are required.

We define three typologies of anomaly:

- **Warnings:** these anomalies do not require shutting the engine down. They point out to situations that are not dangerous at the moment, but the operator must take some action because, if ignored, they could degenerate in one of the following categories.
- **Deactivations:** these anomalies require shutting the engine down. They create hazards for the loads but not immediately for the engine. For this reason, the controller opens immediately the GCB breaker, then it stops the engine with standard procedure, that is with the cooling cycle. However, it is not possible to restart the engine until the anomaly has not been acknowledged.
- **Alarms:** these anomalies require shutting the engine down. They create hazards for the loads and/or for the engine and the generator. For this reason, the controller opens immediately the GCB breaker and stops the engine immediately with emergency procedure, that is without the cooling cycle. It is not possible to restart the engine until the anomaly is acknowledged.

A block can be activated if no other blocks are already active (there are some exceptions, which will be listed below). Deactivations and early warnings can be present, though.

A deactivation can be activated only if no alarms and deactivations are already active. Some other warnings can be active.

To activate a warning, either blocks nor deactivations must be present. Some other warnings can be active.

When an anomaly activates, the controller performs the following:

- It activates the internal horn and, if configured, also the external one. To that purpose, in fact, you can configure an output of the controller with the feature DOF.3152 – "Outside siren". The output is controlled together with the inside beeper; the purpose is that of using a more powerful beeper or a lamp.
- Prompts the page S.02 on the multifunction display. This page shows the fault numeric code and the symbol related to the anomaly. The numeric code flashes to indicate that the anomaly hasn't been recognized by the operator yet.
- It activates the flashing of the "ALARM" indicator light, if the anomaly belongs to the pre-alarm category, or it turns it on if the anomaly belongs to the category of discharges, deactivations or interlocks.
- If the anomaly is not a warning, the controller disconnects the generator from the load and stops the engine (with or without the cooling cycle).

Three operations can be carried out on an anomaly:

- **Silence** the horn.
- **Acknowledge** anomaly: means informing the controller that the operator has taken note of it.
- **Reset**: this tells the controller to act as if the anomaly was never active.

10.1 Silencing the horn

The operator can silence the horn:

- By pressing any button on controller panel. **This operation also acknowledges the anomaly, which stops flashing on the display.**
- Using a Modbus command via USB. The commands can be protected by a password (P.0004) which has to be sent before any command, and can be deactivated through a digital input (DIF.2706). To send the command, it is necessary to write in sequence (within 5 seconds):
 - HOLDING REGISTER 101: write the password configured with the parameter P.0004.
 - HOLDING REGISTER 102: write value "51".

Parameter P.0491 (Horn duration) influences the management of the controller's horn.

- If set to zero, the horn will be never activated.
- If set to 999, the horn will be activated when a new anomaly arises, and will be deactivated with the above-mentioned procedure.
- If the hooter is set on a value between 1 and 998, it will be activated when a new anomaly arises and deactivated through the described procedure above, or when the configured time span has elapsed.

Silencing the horn is not the same as acknowledging the anomaly: in fact, it continues to flash on page S.02.

10.2 Acknowledging anomaly

The operator can "acknowledge" the anomaly (sequence ISA2C) in two ways:

- By pressing any button on controller panel. **If you press any button with siren on, it also stops even the siren.**
- By using a command from the serial port. The commands can be protected by a password (P.0004) which has to be sent before any command, and can be deactivated through a digital input (DIF.2706). To send the command, it is necessary to write in sequence (within 5 seconds):
 - HOLDING REGISTER 101: write the password configured with the parameter P.0004.
 - HOLDING REGISTER 102: write value "52". This command also silences the horn, if active.

When the anomaly has been acknowledged, it stops flashing on page S.02 ANOMALIES. Once acknowledged, if it is only a warning, it is automatically cancelled, if the cause that triggered it is no longer present.

Instead, if the cause disappears before the anomaly is acknowledged, the same will remain on the display.

10.3 Acknowledging anomaly

An anomaly can be cancelled only when the cause that activated it is no more present.

The controller automatically resets all the acknowledged warnings when their cause is no longer active.

On the contrary, to cancel discharges and shut-downs, it is necessary to follow one of the below procedures:

- By putting the controller in OFF/RESET mode.
- Using a Modbus command via USB. The commands can be protected by a password (P.0004) which has to be sent before any command, and can be deactivated through a digital input (DIF.2706). To send the command, it is necessary to write in sequence (within 5 seconds):
 - HOLDING REGISTER 101: write the password configured with the parameter P.0004.
 - HOLDING REGISTER 102: write value "53".
- Using a digital input configured with the feature DIF.2001 - "Alarms reset command". When the input becomes active, the controller executes a reset of all anomalies.

10.4 Events and signalling relative to the anomalies

All anomalies are being recorded (each with its own code) in the events log.

There are some features available for configuring the digital outputs related to anomalies:

- DOF.3151 ("reset of anomalies"). The board activates this output for one second when the internal sequence for the cancellation of anomalies is carried out. With this procedure, it is also possible to reset externally managed anomalies.
- DOF.3152 ("external horn"). This output is activated and deactivated along with the internal hooter. It can be used to control a more powerful hooter and/or a lamp.
- DOF.4001 - ("Warnings"). The output is "active" if there is at least one pre-alarm.
- DOF.4003: the output will be activated if at least a deactivation is active.
- DOF.4004: the output will be activated if at least a shut-down is active.
- DOF.4005: the output will be activated if at least a block or a deactivation are active.
- DOF.4031: the output will be activated if at least an anomaly linked to the generator is active.
- DOF.4032: the output will be activated if at least an anomaly linked to the engine is active.
- DOF.4034: the output will be activated if at least an anomaly linked to the fuel is active.
- DOF.4035: the output will be activated if at least an anomaly linked to switches is active.



In addition, the controller makes available the anomalies statuses for the AND/OR logics by means of the following internal statuses:

- ST.008 - "Pre-alarm cumulative"
- ST.010 - "Deactivations cumulative"
- ST.011 - "Interlocks cumulative"
- ST.012 - "Unacknowledged warnings cumulative"
- ST.014 - "Unacknowledged deactivations cumulative"

- ST.015 - "Unacknowledged interlocks cumulative"

10.5 Anomalies connected to digital inputs

Every digital input of the controller can be used to activate anomalies. These anomalies are divided into two kinds:

- **Specifics.** They are configured with functions DIF.4201 and following. The controller knows the way these anomalies have to be managed and has already error symbols (not configurable) related to each anomaly.
- **Generic.** They are configured with functions from DIF.4001 to DIF.4064. For  these anomalies, the controller will show the generic symbol: . Also, using the suitable functions, the controller can be taught on how to manage the anomaly.

The specific anomalies will be described in the following paragraphs: in the description we will always refer to the parameters related to the digital input **T.16** of the controller (P.2001 and P.2002). In doc [1] there is a table showing the parameters to be used for each digital input.

What stated above is true also for generic anomalies. They will not be described in the following paragraphs, because they will be infinite repetitions of the same description for each input. They are described here instead, mentioning the parameters for input **T.16** of the controller.

The controller assigns the numeric codes from 701 to 742 to the generic anomalies related to the digital inputs (docs [1] contain a table showing the code per each input). Using the parameter which configures the function (P.2001), it is possible to select the type of anomaly (warning, deactivation or block) and also to define the conditions in which the anomaly has to be managed.



ATTENTION! by setting the delay to "0", the acquisition of the anomaly is disabled.

In the following list the functions for the configuration of digital inputs used to manage the generic anomalies are listed. They are grouped four by four: the four functions for each group define the type of anomaly (see documents e [1] for the list of functions).

- DIF.4001, DIF.4003, DIF.4004. The board will activate this anomaly if the digital input is uninterruptedly active for the configured (P.2002) time span.
- DIF.4011, DIF.4013, DIF.4014. The anomaly can be activated only if the engine has been started by controller, and if it is in motion from, at least, the time span configured in P.0216 ("engine protection masking time"). The board will activate this anomaly if the digital input is uninterruptedly active for the configured (P.2002) time span.
- DIF.4021, DIF.4023, DIF.4024. The anomaly can be activated only if GCB switch is closed. The board will activate this anomaly if the digital input is uninterruptedly active for the configured (P.2002) time span.
- DIF.4031, DIF.4033, DIF.4034. The anomaly can be activated only if the fuel electromagnetic valve is open (**FUEL** active, see 9.5.2). The board will activate this anomaly if the digital input is uninterruptedly active for the configured (P.2002) time span.
- DIF.4051. The board will activate this anomaly if the digital input is uninterruptedly active for the configured (P.2002) time span. The anomaly activation causes the stopping of the fuel pump.

10.6 Anomalies connected to analogue inputs

For each analogue input it is possible to set two thresholds on the acquired measure and each threshold can activate an anomaly. These anomalies are generic, as the controller does not know how they have to be managed. And does not have pre-defined alarm messages. They will not be described in the following paragraphs, because they will be infinite repetitions of the same description for each analogue input. They are described here instead, mentioning the parameters for input **T.09**.

The controller assigns the numeric codes from 301 to 312 to the generic anomalies related to the digital inputs (doc [1] contains a table showing the code per each input). The controller will show a generic symbol, followed by an arrow to indicate:

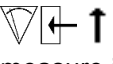
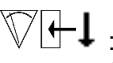
-  : "High value from analogue input:" if the anomaly is activated when the measure is higher than the threshold.
-  : "Low value from analogue input:" if the anomaly is activated when the measure is lower than the threshold.

For each analogue input, there are six parameters available for the management of thresholds, three for each threshold (P.4003, P.4004 and P.4005 for the first threshold of the first analogue input; P.4006, P.4007 and P.4008 for the second threshold of the first analogue input).

Besides the threshold value (P.4003 or P.4006) and the delay to be managed (P.4004 or P.4007), the operator has to configure the operations connected to the threshold (P.4005 or P.4008). The parameter that configures the actions is managed through bits (every bit enables/disables a function connected to the threshold). A description for these parameters follows 5.7.2

 **ATTENTION!** by setting the delay to "0", the acquisition of the anomaly is not disabled.

10.7 Anomalies list

 **INFORMATION!** Since you cannot define in advance neither which digital or analogue inputs (those from the controller or from the additional modules) will be used, nor what function will they perform, the list below refers, as an example, to the parameters of the first configurable input **T.09**. The symbol (*) or the indication "or equivalent for the other inputs" next to a parameter show that the same varies according to the particular input configured.

From this point on, words **enabling** and **activation** will be utilized:

- Enabling an anomaly means having the minimum conditions necessary in order for the controller to observe the cause.
- Activation of an anomaly refers to the cause after enabling.

01 – Minimum generator voltage

Icon:	
Type:	Deactivation
Category:	Loads protection
Related parameters:	P.0101 Number of generator phases P.0102 Generator rated voltage P.0202 Hysteresis of generator measures P.0301 Threshold for minimum voltage P.0302 Delay for minimum voltage
To disable:	P.0302=0
Enabled in:	MAN, AUTO, TEST, REMOTE START

This protection is only enabled if the controller has been started by the controller (if the command for the fuel solenoid is activated) and is disabled in the engine start/stop phases. It is enabled the first time (from engine start) the generator's frequency and voltages enter the tolerance range (see generator sequence description). In MAN it is only enabled if the GCB breaker is closed. It is enabled if, under the conditions previously mentioned, at least one of the generator voltages is continuously below the threshold P.0301 for the time P.0302.

02 – Maximum generator voltage

Icon: 

Type: **Alarm**

Category: **Generator/Loads protection**

Related parameters: **P.0101** Number of generator phases
P.0102 Generator rated voltage
P.0202 Hysteresis of generator measures
P.0303 Threshold for minimum voltage
P.0304 Delay for minimum voltage

To disable: **P.0304=0**

Enabled in: **MAN, AUTO, TEST, REMOTE START**

This protection is only enabled if the controller has been started by the controller (if the command for the fuel solenoid is activated) and is disabled in the engine start/stop phases. It is enabled if, under the conditions previously mentioned, at least one of the generator voltages exceeds continuously the threshold P.0303 for the time P.0304.

03 – Minimum generator frequency

Icon: 

Type: **Deactivation**

Category: **Loads protection**

Related parameters: **P.0105** Rated frequency
P.0305 Threshold for minimum frequency
P.0306 Delay for minimum frequency

To disable: **P.0306=0**

Enabled in: **MAN, AUTO, TEST, REMOTE START**

This protection is only enabled if the controller has been started by the controller (if the command for the fuel solenoid is activated) and is disabled in the engine start/stop phases. It is enabled the first time (from engine start) the generator's frequency and voltages enter the tolerance range (see generator sequence description). In MAN it is only enabled if the GCB breaker is closed. It is enabled if, under the conditions previously mentioned, the generator frequency is continuously below the threshold P.0305 for the time P.0306.

04 – Maximum generator frequency

Icon: 

Type: **Alarm**

Category: **Generator/Loads protection**

Related parameters: **P.0105** Rated frequency
P.0307 Threshold for maximum frequency
P.0308 Delay for maximum frequency

To disable: **P.0308=0**

Enabled in: **MAN, AUTO, TEST, REMOTE START**

This protection is only enabled if the controller has been started by the controller (if the command for the fuel solenoid is activated) and is disabled in the engine start/stop phases. It is enabled if, under the conditions previously mentioned, the generator frequency exceeds continuously the threshold P.0307 for the time P.0308.

05 – Belt break (alternator battery-charger failure)

Icon: 

Type: **Configurable (Block/Deactivation/Warning)**

Category: **Engine protection**

Related parameters: **P.4041** Function for the analogue input (D+)
P.0230 Threshold for engine idle (D+)
P.0231 Threshold for engine started (D+)
P.0357 Action for belt break
P.0349 Delay belt break

To disable: **P.0349=0**

Enabled in: **MAN, AUTO, TEST, REMOTE START**

This protection is enabled only if the controller is configured to use signal D+ (P.4041 = AIF.1300 - "Signal D+") and if that signal is physically linked to connector JL. The protection is enabled if the engine was started from the controller (if the command for fuel solenoid is activated). It is activated if voltage on the D + signal remains below threshold P.0230 consecutively for P.0349 time.

06 – Maximum current

Icon: 

Type: **Configurable (Block/Deactivation)**

Category: **Generator protection**

Related parameters: **P.0101** Number of generator phases
P.0102 Generator rated power
P.0106 Generator rated power
P.0309 Threshold for maximum current
P.0310 Delay for maximum current
P.0323 Action for maximum current and short circuit

To disable: **P.0310=0**

Enabled in: **MAN, AUTO, TEST, REMOTE START**

The controller realises a depending on time protection in current (which therefore intervenes as quickly as the current is in overload). The used curve is named EXTREMELY INVERSE, and implements an I²t. It is a generator protection as it limits the thermal accumulation of the generator during the supply phase. As engine protection, the maximum power protection must be used, that is independent from the load type.

A maximum current threshold and the maximum time the generator can work with this current are defined. If the current is lower than the defined threshold, the protection does not activate. If the current rises above the threshold, the protection activates with a time inversely proportional to the over current. In order to correctly set the thresholds, perform the following steps:

- Define the system rated current. It can be inferred from the system rated power (P.0106 generator rated power kVA) and rated voltage (P.0102 Genset rated voltage):

- Single-phase system:
$$I_{nom} = \frac{P.0106 \times 1000}{P.0102}$$

o Three-phases system:
$$I_{nom} = \frac{[(P.0106 \times 1000) / 3]}{(P.0102 / \sqrt{3})}$$

For example, on the three-phase system at 400 V out of 200 kVA, the rated current is approximately 289 A.

When the parameter P.0106 “Generator rated power kVA” is set after correct configuration of parameters P.0101 “Number of generator phases” and P.0102 “Generator rated voltage”, the display shows the rated current.

- Set the maximum current threshold with the parameter P.0309, as a percentage of the rated current. In the previous example, setting a 350 A maximum threshold, requires entering 121 (%) in parameter P.0309.
- Set the action time in the parameter P.0310: the protection will be activated within time set if the current is constantly equal to the threshold P.0309 multiplied by $\sqrt{2}$. In the previous example, if you set 10 s, the protection will activate in 10 seconds with approx. 495 A of constant load; in a shorter time if the current is higher; in a longer time if the current is lower; and it will never do if the current is lower than 350 A.

In order to calculate the intervention time for a preferred current, please use the following formula:

$$t_1 = \frac{P.0310}{\left(\frac{I}{P.0309}\right)^2 - 1}$$

Where I is the current in the circuit.

Please remember that the protection is performed by performing the integral of the current value during time; therefore, current values above the rated threshold all concur to define the intervention time, with their instant weight resulting from the above formula. Thus, only way to experimentally verify this formula is to switch instantaneously from a normal load situation to an overload situation.

The following graph shows the curve used for enabling protection, with a value of P.0310 set to 60 seconds (I is the maximum current):

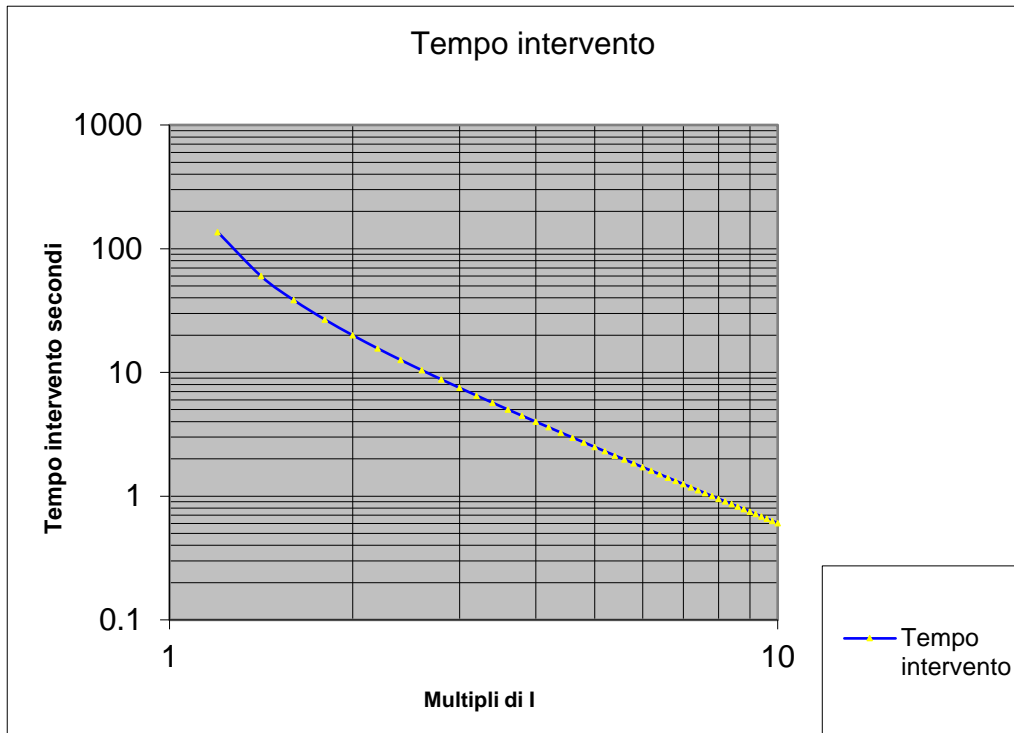

This protection is only enabled if the controller has been started by the controller (if the command for the fuel solenoid is activated) and is disabled in the engine start/stop phases. Type is configurable with parameter P.0323 (though it cannot be configured as warning).

07 – Manual stop while in AUTO

Icon: 

Type: **Alarm**

Category: **General**

Related parameters: **P.0495** Keyboard options

To disable: **P.0495=1**

Enabled in: **AUTO, TEST, REMOTE START**

This protection is always enabled for stop command through the serial ports and it can be disabled for the “STOP” button by setting in parameter P.0495 the value 1. It is activated when pressing the “**STOP**” button on the front panel or sending a stop command via USB, while in **AUTO, TEST** or **REMOTE START**.

08 – Operating conditions failure

Icon: 

Type: **Alarm**

Category: **General**

Related parameters: **P.0217** Maximum time for full speed conditions

To disable: **P.0217=0**

Enabled in: **AUTO, TEST, REMOTE START**

This protection is only enabled if the engine has been started by the controller (if the command for the fuel solenoid is activated). It is activated when the generator voltages and frequency are not steady within tolerance range within time P.0217 from the engine running acknowledgement (or from the end of the engine’s idle cycle, if enabled).

The protection is also enabled in MAN mode if parameter P.0802 is set to “11-DRIVE”. In this case the voltage thresholds are not used and the frequency thresholds are applied to the rated engine speed.

13 – Mains circuit breaker (MCB) not closed

Icon: 

Type: **Warning**

Category: **General, loads protection**

Related parameters: **P.2001** Function of input T.16 or equivalent for other inputs
P.2002 Delay for input T.16 or equivalent for other inputs

To disable: **P.2002=0**

Enabled in: **MAN, AUTO, TEST, REMOTE START**

This protection is enabled only when one of the digital inputs of the controller is configured to acquire the MCB status (feature DIF.3002 - “MCB breaker status” in parameter P.2001 or equivalent for the other inputs) and if a time other than zero has been set for said input (parameter P.2002 or equivalent). It activates only when MCB is commanded to close and the status acquired is continuously “not active” (open) for the time set.

14 – Genset circuit breaker (GCB) not closed

Icon: 

Type: **Deactivation/Warning**

Category: **General**

Related parameters: **P.2001** Function of input T.16 or equivalent for other inputs
P.2002 Delay for input T.16 or equivalent for other inputs

To disable: **P.2002=0**

Enabled in: **MAN, AUTO, TEST, REMOTE START**

This protection is enabled only when one of the digital inputs of the controller is configured to acquire the MCB status (feature DIF.3001 - “MCB breaker status” in parameter P.2001 or equivalent for the other inputs) and if a time other than zero has been set for said input (parameter P.2002 or equivalent). It activates only when GCB is commanded to close and the status acquired is continuously “not active” (open) for the time set. It only operates as warning, no automatic change-over to the mains is provided.

16 – Short circuit on the generator

Icon: 

Type: **Configurable (Block/Deactivation)**

Category: **Generator protection**

Related parameters: **P.0101** Number of generator phases
P.0102 Generator rated voltage
P.0106 Generator rated power
P.0311 Threshold for short circuit
P.0312 Delay for short circuit
P.0323 Action for maximum current and short circuit

To disable: **P.0312=0**

Enabled in: **MAN, AUTO, TEST, REMOTE START**

In addition to the maximum current protection, the controller also provides a short circuit protection for quick intervention independently of timing for the maximum current protection curve. Protection is given by setting a threshold (P.0311) expressed as a percentage of the

system rated current (see maximum current protection to calculate rated current with parameters P.0101, P.0102 and P.0106). It is only enabled if the controller has been started by the controller (if the command for the fuel solenoid is activated) and is disabled in the engine start/stop phases. It activates when the current on at least one phase remains continuously above the P.0311 threshold for time P.0312. Type is configurable with parameter P.0323 (though it cannot be configured as warning).

18 – Overspeed (from measure, only for DRIVE applications).



Icon:

Type: **Alarm**

Category: **Engine protection**

Related parameters: **P.0105** Rated frequency (Hz)
P.0105 @ 50Hz Engine's nominal speed (Primary = 1500 rpm)
P.0105 @ 60Hz Engine's nominal speed (Secondary = 1800 rpm)
P.0331 Threshold of maximum speed from engine nominal speed (in %)
P.0332 Delay for maximum speed from engine nominal speed
P.0700 Engine type

To disable: **P.0332=0**

Enabled in: **MAN, AUTO, TEST, REMOTE START**

The protection will be enabled if the controller measures the rotation speed of the engine. The protection is enabled only with the engine running (FUEL solenoid activated) and after the engine speed has been considered "within tolerance". It is disabled during the starting and stopping phase of the engine.

It activates if the acquired speed measure is higher than threshold P.0331 continuously, for time P.0332. P.0331 threshold is expressed in percentage: this percentage is applied to the rated rotation speed of the engine.

19 – Overspeed (from frequency).



Icon:

Type: **Alarm**

Category: **Engine protection**

Related parameters: **P.0105** Rated frequency (Hz)
P.0331 Threshold of maximum speed from frequency (in %)
P.0332 Delay for maximum speed from frequency

To disable: **P.0332=0**

Enabled in: **MAN, AUTO, TEST, REMOTE START**

This protection is only enabled if the controller has been started by the controller (if the command for the fuel solenoid is activated) and is disabled in the engine start/stop phases. It activates if the generator frequency exceeds threshold P.0331 continuously, for time P.0332.

 **INFORMATION!** Parameter P.0331 is expressed in percentage with respect to P.0105.

21 – Engine not stopped.



Icon:

Type: **Alarm**

Category: **General**
 Related parameters: **P.0214 Duration of stopping cycle (s)**
 To disable: **P.0214=0**
 Enabled in: **AUTO, TEST, REMOTE START**

This protection is only enabled if the engine has been started by the controller (if the command for the fuel solenoid is activated). It activates if the engine does not stop within the time set in P.0214 (since the stop command).

This interlock can be activated even if another one is already active.

22 – Over crank

Icon: 
 Type: **Alarm**
 Category: **Battery protection**
 Related parameters: **P.0211 Numbers of starting attempts**
 To disable: -
 Enabled in: **AUTO, TEST, REMOTE START**

This protection is always enabled. It activates if the controller has performed P.0211 consecutive engine start attempts (auto start) without success (engine running).

23 – Mains circuit breaker (MCB) not open

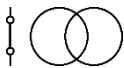
Icon: 
 Type: **Deactivation/Warning**
 Category: **General**
 Related parameters: **P.2001** Function of input T.16 or equivalent for other inputs
P.2002 Delay for input T.16 or equivalent for other inputs
 To disable: **P.2002=0**
 Enabled in: **MAN, AUTO, TEST, REMOTE START**

This protection is enabled only when one of the digital inputs of the controller is configured to acquire the MCB status (feature DIF.3002 - “MCB breaker status” in parameter P.2001 or equivalent for the other inputs) and if a time other than zero has been set for said input (parameter P.2002). It activates only when MCB is commanded to open and the status acquired is continuously “active” (closed) for the time set. In auto mode it activates after three consecutive attempts. It can be:

- **Deactivation:** when the controller is in one of the AUTO modes and if the stable command is used for MCB closing (feature DOF.2004 in one of the digital outputs).
- **Warning:** for all other events.

24 – Genset circuit breaker (GCB) not open

Icon: 
 Type: **Block/Warning**
 Category: **General**
 Related parameters: **P.2001 Function of input T.16** or equivalent for other inputs
P.2002 Delay for input T.16 or equivalent for other inputs
 To disable: **P.2002=0**

Enabled in: **MAN, AUTO, TEST, REMOTE START**

This protection is enabled only when one of the digital inputs of the controller is configured to acquire the GCB status (feature DIF.3001 - "GCB breaker status" in parameter P.2001 or equivalent for the other inputs) and if a time other than zero has been set for said input (parameter P.2002 or equivalent). It activates only when GCB is commanded to open and the status acquired is continuously "active" (closed) for the time set. In auto mode it activates after three consecutive attempts. It can be:

- **Block:** when the controller is in AUTO mode with engine running and only if the stable command is used for GCB closing (function DOF.2034 in one of the digital outputs).
- **Warning:** for all other events.

25 – Minimum fuel level (from contact)

Icon: 

Type: **Alarm**

Category: **General**

Related parameters: **P.2001 Function of input T.16** or equivalent for other inputs
P.2002 Delay for input T.16 or equivalent for other inputs

To disable: **P.2002=0**

Enabled in: **MAN, AUTO, TEST, REMOTE START**

This protection is enabled only when one of the digital inputs of the controller is configured to acquire the minimum fuel level contact of the float (feature DIF.4211 - "Minimum fuel level" in parameter P.2001 or equivalent for the other inputs) and if a time other than zero has been set for said input (parameter P.2002 or equivalent). Active if the configured input remains continuously active for the associated time.

26 – Minimum fuel level (from analogue sensor)

Icon: 

Type: **Alarm**

Category: **General**

Related parameters: **P.4009 (*) Function for input T.13 (FL) Fuel level (VDO) / General fuel level** or equivalent parameter for the other inputs
P.0347 Threshold for minimum fuel level (%)
P.0348 Delay for minimum fuel level

To disable: **P.0348=0**

Enabled in: **MAN, AUTO, TEST, REMOTE START**

It is enabled only when the controller is configured to use the analogue fuel level sensor (P.4009 suitably configured), or if said sensor is physically connected to the device terminal. It activates if the level measure remains continuously below or equal to threshold P.0347 (in percentage) for time P.0348.

27 – Low fuel level (from contact)

Icon: 

Type: **Warning**

Category: **General**

Related parameters: **P.2001 Function of input T.16** or equivalent for other inputs
P.2002 Delay for input T.16 or equivalent for other inputs

To disable: **P.2002=0**
 Enabled in: **MAN, AUTO, TEST, REMOTE START**

It is enabled only when one of the digital inputs of the controller is configured to acquire the low fuel level contact of the float (feature DIF.4212 - "Low fuel level" in parameter P.2001 or equivalent for the other inputs) and if a time other than zero has been set for said input (parameter P.2002 or equivalent). Active if the configured input remains continuously active for the associated time.

28 – Low fuel level (from analogue sensor)

Icon: 

Type: **Warning**

Category: **General**

Related parameters: **P.4009 (*) Function for input T.13 (FL)** Fuel level (VDO) / General fuel level or equivalent parameter for the other inputs
P.0345 Threshold for low fuel level (%)
P.0346 Delay for low fuel level

To disable: **P.0346=0**
 Enabled in: **MAN, AUTO, TEST, REMOTE START**

It is enabled only when the controller is configured to use the analogue fuel level sensor (P.4009 suitably configured), or if said sensor is physically connected to the device terminal. It activates if the level measure remains continuously below or equal to threshold P.0345 (in percentage) for time P.0346.

29 – High fuel level (from contact)

Icon: 

Type: **Warning**

Category: **General**

Related parameters: **P.2001 Function of input T.16** or equivalent for other inputs
P.2002 Delay for input T.16 or equivalent for other inputs

To disable: **P.2002=0**
 Enabled in: **MAN, AUTO, TEST, REMOTE START**

It is enabled only when one of the digital inputs of the controller is configured to acquire the high fuel level contact of the float (feature DIF.4213 - "High fuel level" in parameter P.2001 or equivalent for the other inputs) and if a time other than zero has been set for said input (parameter P.2002 or equivalent). Active if the configured input remains continuously active for the associated time.

30 – High fuel level (from analogue sensor)

Icon: 

Type: **Warning**

Category: **General**

Related parameters: **P.4009 (*) Function for input T.13 (FL)** Fuel level (VDO) / General fuel level or equivalent parameter for the other inputs
P.0343 Threshold for high fuel level
P.0344 Delay for high fuel level

To disable: **P.0344=0**
 Enabled in: **MAN, AUTO, TEST, REMOTE START**

It is enabled only when the controller is configured to use the analogue fuel level sensor (P.4009 suitably configured), or if said sensor is physically connected to the device terminal. It activates if the level measure remains continuously above or equal to threshold P.0343 (in percentage) for time P.0344.

31 – High coolant temperature (from contact)

Icon: 

Type: **Warning**

Related parameters: **P.2001 Function of input T.16** or equivalent for other inputs
P.2002 Delay for input T.16 or equivalent for other inputs
P.0216 Time of engine protection mask

To disable: **P.2002=0**

Enabled in: **MAN, AUTO, TEST, REMOTE START**

This protection is enabled only when one of the digital inputs of the controller is configured to acquire the external high coolant temperature contact (feature DIF.4231 - “High coolant temperature” in parameter P.2001 or equivalent for the other inputs) and if a time other than zero has been set for said input (parameter P.2002 or equivalent). It is only enabled if the controller has been started by the controller (if the command for the fuel solenoid is activated) and is disabled in the engine start/stop phases. It activates if the input configured is continuously “active” for the time configured, but only after the time P.0216 (oil mask) from engine start has elapsed (this is to allow you to start the engine idle, to cool it off)

32 – High coolant temperature (from analogue sensor)

Icon: 

Type: **Warning**

Category: **Engine protection**

Related parameters: **P.4025 Function for analogue input T.15 (CT)** or equivalent parameter for other inputs
P.0216 Time for engine protection mask
P.0335 Threshold for high cooling temperature
P.0336 Delay for high cooling temperature
P.0700 Engine type

To disable: **P.0336=0**

Enabled in: **MAN, AUTO, TEST, REMOTE START**

This protection is enabled only if the controller acquires the measure of the engine coolant temperature. It can acquire it from its input (T.15, P.4025 suitably configured) or from CAN-BUS (P.0700 other than zero). It is only enabled if the controller has been started by the controller (if the command for the fuel solenoid is activated) and is disabled in the engine start/stop phases. It activates if the temperature remains continuously above or equal to threshold P.0335 for time P.0336, but only after the time P.0216 (oil mask) from engine start has elapsed (this is to allow you to start the engine idle, to cool it off).

33 – Maximum coolant temperature (from contact)

Icon: 

Type: **Alarm**

Category: **Engine protection**

Related parameters: **P.2001 Function of input T.16** or equivalent for other inputs
P.2002 Delay for input T.16 or equivalent for other inputs
P.0216 Time of engine protection mask

To disable: **P.2002=0**

Enabled in: **MAN, AUTO, TEST, REMOTE START**

This protection is enabled only when one of the digital inputs of the controller is configured to acquire the external maximum coolant temperature contact (feature DIF.4231 - "Maximum coolant temperature" in parameter P.2001 or equivalent for the other inputs) and if a time other than zero has been set for said input (parameter P.2002 or equivalent). It is only enabled if the controller has been started by the controller (if the command for the fuel solenoid is activated) and is disabled in the engine start/stop phases. It activates if the input configured is continuously "active" for the time configured, but only after the time P.0216 (oil mask) from engine start has elapsed (this is to allow you to start the engine idle, to cool it off)

34 – Maximum coolant temperature (from analogue sensor)

Icon: 

Type: **Alarm**

Category: **Engine protection**

Related parameters: **P.4025 Function for analogue input T.15 (CT)** or equivalent parameter for other inputs
P.0216 Time for engine protection mask
P.0337 Threshold for maximum cooling temperature
P.0338 Delay for maximum cooling temperature
P.0700 Engine type

To disable: **P.0338=0**

Enabled in: **MAN, AUTO, TEST, REMOTE START**

This protection is enabled only if the controller acquires the measure of the engine coolant temperature. It can acquire it from its input (T.15, P.4025 suitably configured) or from CAN-BUS (P.0700 other than zero). It is only enabled if the controller has been started by the controller (if the command for the fuel solenoid is activated) and is disabled in the engine start/stop phases. It activates if the temperature remains continuously above or equal to threshold P.0337 for time P.0338, but only after the time P.0216 (oil mask) from engine start has elapsed (this is to allow you to start the engine idle, to cool it off).

35 – Maximum oil temperature (from analogue sensor)

Icon: 

Type: **Alarm**

Category: **Engine protection**

Related parameters: **P.4025 Function for analogue input T.15 (CT)** or equivalent parameter for other inputs
P.0216 Time for engine protection mask
P.0375 Threshold for maximum oil temperature (°C)
P.0376 Delay for maximum oil temperature
P.0700 Engine type

To disable: **P.0376=0**

Enabled in: **MAN, AUTO, TEST, REMOTE START**

This protection is enabled only if the controller acquires the measure of the engine oil temperature. It can acquire it from analogue input T.15 (P.4025) or from CAN-BUS (P.0700 other than zero). It is only enabled if the controller has been started by the controller (if the command for the fuel solenoid is activated) and is disabled in the engine start/stop phases. It

activates if the measure is continuously higher than or equal to the threshold P.0375 for time P.0376, but only after the time P.0216 (oil mask) since engine start has elapsed.

37 – Starter battery voltage, low

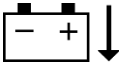
Icon: 

Type: **Warning**

Category: **Battery protection**

Related parameters: **P.0362** Threshold for low battery voltage (%)
P.0363 Delay for low battery voltage

To disable: **P.0363=0**

Enabled in: **MAN, AUTO, TEST, REMOTE START**

It is always enabled except when the cranking motor is activated. It activates if the battery voltage is continuously lower than the threshold P.0362 for time P.0363.

The threshold P.0362 is expressed as a percentage of the rated battery voltage which is not configurable but is automatically selected by the controller between 12 e 24 Vdc. Selection is made when the controller is powered and every time it is forced in **OFF_RESET**. If the controller previously sensed a value lower than, or equal to, 17V, it considers to be powered by a 12V battery, otherwise it will consider a 24 V rated voltage.

38 – Starter battery voltage, high

Icon: 

Type: **Warning**

Category: **Battery protection**

Related parameters: **P.0364** Threshold for high battery (%)
P.0365 Delay for high battery voltage

To disable: **P.0365=0**

Enabled in: **MAN, AUTO, TEST, REMOTE START**

This protection is always enabled, except when the starter motor command is activated. It activates if the battery voltage is continuously above threshold P.0364 for time P.0365.

The threshold P.0364 is expressed as a percentage of the rated battery voltage which is not configurable but is automatically selected by the controller between 12 e 24 Vdc. Selection is made when the controller is powered and every time it is forced in **OFF_RESET**. If the controller previously sensed a value lower than, or equal to, 17V, it considers to be powered by a 12V battery, otherwise it will consider a 24V rated voltage.

39 – Service required

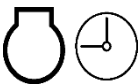
Icon: 

Type: **Configurable (Warning/Block/Deactivation)**

Category: **General**

Related parameters: **P.0424** Interval for service 1 (working hour)
P.0425 Type of action for service 1

To disable: **P.0424=0**

Enabled in: **MAN, AUTO, TEST, REMOTE START**

It activates after P.0424 engine running hours since parameter P.0424 was last set, by issuing a warning, or triggering a deactivation or an interlock, based on the settings of the P.0425 parameter. It cannot be cancelled even disconnecting the controller's power supply. Only

possible setting P.0424 again, setting it to zero to disable the function or confirming the actual value or setting a new one.

Engine operating hours are counted even when engine is not started by the controller.

To be programmed, parameters P.0424 and P.0425 require “installer” access level: this function can be used for genset rental in order to lock the genset when the established hours are elapsed.

41 – Minimum oil pressure (from contact)

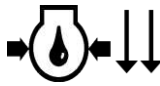
- Icon: 
- Type: **Alarm**
- Category: **Engine protection**
- Related parameters: **P.2001 Function of input T.16** or equivalent for other inputs
P.2002 Delay for input T.16 or equivalent for other inputs
P.0216 Time of engine protection mask
- To disable: **P.2002=0**
- Enabled in: **MAN, AUTO, TEST, REMOTE START**

This protection is enabled only when one of the digital inputs of the controller is configured to acquire the external minimum oil pressure contact (feature DIF.4221 - “Minimum oil pressure” in parameter P.2001 or equivalent for the other inputs) and if a time other than zero has been set for said input (parameter P.2002 or equivalent). It is only enabled if the controller has been started by the controller (if the command for the fuel solenoid is activated) and is disabled in the engine start/stop phases. It activates if the input configured is continuously “active” for the time configured, but only after the time P.0216 (oil mask) from engine start has elapsed (this is to allow you to ignore the normal status of low pressure, which occurs at start-up).

42 – Minimum oil pressure (from analogue sensor)

- Icon: 
- Type: **Alarm**
- Category: **Engine protection**
- Related parameters: **P.4017 Function for analogue input T.14 (OP)** or equivalent parameter for other inputs
P.0216 Time for engine protection mask
P.0341 Threshold for minimum oil pressure
P.0342 Delay for minimum oil pressure
P.0700 Engine type
- To disable: **P.0342=0**

This protection is enabled only if the controller acquires the measure of the engine lubrication oil pressure. It can acquire it from its input T.14 (with P.4017 suitably configured) or from CAN-BUS (P.0700 other than zero). It is only enabled if the controller has been started by the controller (if the command for the fuel solenoid is activated) and is disabled in the engine start/stop phases. It activates if the pressure is continuously lower than or equal to threshold P.0341 for time P.0342, but only after the time P.0216 (oil mask) from engine start has elapsed (this is to allow you to ignore the normal status of low pressure, which occurs at start-up).

43 – Low oil pressure (from contact)

- Icon: 
- Type: **Warning**

Category: **Engine protection**

Related parameters: **P.2001 Function of input T.16** or equivalent for other inputs
P.2002 Delay for input T.16 or equivalent for other inputs
P.0216 Time of engine protection mask

To disable: **P.2002=0**

Enabled in: **MAN, AUTO, TEST, REMOTE START**

This protection is enabled only when one of the digital inputs of the controller is configured to acquire the external low oil pressure contact (feature DIF.4222 - "Low oil pressure" in parameter P.2001 or equivalent for the other inputs) and if a time other than zero has been set for said input (parameter P.2002 or equivalent). It is only enabled if the controller has been started by the controller (if the command for the fuel solenoid is activated) and is disabled in the engine start/stop phases. It activates if the input configured is continuously "active" for the time configured, but only after the time P.0216 (oil mask) from engine start has elapsed (this is to allow you to ignore the normal status of low pressure, which occurs at start-up).

44 – Low oil pressure (from analogue sensor)

Icon: 

Type: **Warning**

Category: **Engine protection**

Related parameters: **P.4017 Function for analogue input T.14 (OP)** or equivalent parameter for other inputs
P.0216 Time for engine protection mask
P.0339 Threshold for low oil pressure
P.0340 Delay for low oil pressure
P.0700 Engine type

To disable: **P.0340=0**

Enabled in: **MAN, AUTO, TEST, REMOTE START**

This protection is enabled only if the controller acquires the measure of the engine lubrication oil pressure. It can acquire it from its input T.14 (with P.4017 suitably configured) or from CAN-BUS (P.0700 other than zero). It is only enabled if the controller has been started by the controller (if the command for the fuel solenoid is activated) and is disabled in the engine start/stop phases. It activates if the pressure is continuously lower than or equal to threshold P.0339 for time P.0340, but only after the time P.0216 (oil mask) from engine start has elapsed (this is to allow you to ignore the normal status of low pressure, which occurs at start-up).

48 – Emergency stop

Icon: 

Type: **Alarm**

Category: **General**

Related parameters: **P.2007 Function of input T.18** or equivalent for other inputs
P.2008 Delay for input T.18 or equivalent for other inputs
P.0216 Time of engine protection mask

To disable: **P.2008=0**

Enabled in: **MAN, AUTO, TEST, REMOTE START**

 **INFORMATION!** by default, input **T.18** is configured with the function of emergency stop. This interlock can be activated even if another one is already active.

It activates if the input that acquires the external contact (function DIF.4201 in parameter P.2007 or equivalent) remains active consecutively for the configured time (P.2008 or equivalent).

It is possible to force the emergency stop alarm manually with a control through the serial ports writing (within 5 seconds) the Modbus registers in sequence:

- HOLDING REGISTER 101: write the password configured with the parameter P.0004.
- HOLDING REGISTER 102: enter the value "99".

49 – Maximum power

Icon:	
Type:	Configurable (Warning/Block/Deactivation)
Category:	Engine protection
Related parameters:	P.0350 Threshold of maximum power (% compared to P.0125) P.0351 Delay for maximum power P.0352 Action for maximum power
To disable:	P.0351=0
Enabled in:	MAN, AUTO, TEST, REMOTE START

This protection is only enabled if the engine has been started by the controller (if the command for the fuel solenoid is activated). This protection is disabled in the engine start/arrest phases. It activates if the system total active power is positive and remains continuously over the threshold P.0350 for time P.0351. With parameter P.0352 it is possible to select the protection to be activated (warning, deactivation, alarm).

52 – Generator voltages unbalance

Icon:	
Type:	Alarm
Category:	Generator protection
Related parameters:	P.0101 Number of generator phases P.0102 Generator rated voltage P.0315 Threshold voltage asymmetry (% phase rated power) P.0316 Delay of voltage asymmetry
To disable:	P.0316=0
Enabled in:	MAN, AUTO, TEST, REMOTE START

This protection is only enabled if the system is three-phase (P.0101=3) and only if the engine has been started by the controller (if the command for the fuel solenoid is activated) and is disabled when the engine is started/stopped. In addition, generator voltage and frequency must be within the tolerance range. Threshold P.0315 is expressed as a percentage of the system rated voltage (phase voltage). It represents the maximum acceptable difference (absolute value) between two phase-to-phase voltages. It activates if the difference between two phase-to-phase voltages (absolute value) is continuously over the threshold P.0315 for time P.0316.

53 – Generator current unbalance

Icon:	
Type:	Alarm
Category:	Generator protection
Related parameters:	P.0101 Number of generator phases P.0102 Generator rated power

P.0106 Generator nominal power
P.0317 Threshold current asymmetry (% rated current)
P.0318 Delay for current asymmetry

To disable: **P.0318=0**

Enabled in: **MAN, AUTO, TEST, REMOTE START**

This protection is only enabled if the system is three-phase and only if the engine has been started by the controller (if the command for the fuel solenoid is activated) and is disabled when the engine is started/stopped. In addition, the generator voltages and frequency must be within the tolerance range and the load must be changed-overt to the generator. Threshold P.0317 is expressed as percentage of the system rated current (refer to the details for maximum current protection to see how to obtain the rated current from P.0102 and P.0106). It represents the maximum acceptable difference (absolute value) between any two-phase currents. The protection activates if the difference between any two currents (absolute value) is continuously over the threshold P.0317 for time P.0318.

54 – High oil temperature (from analogue sensor)



Icon:

Type: **Warning**

Category: **Engine protection**

Related parameters: **P.4025 Function for analogue input T.15 (CT)** or equivalent parameter for other inputs

P.0216 Time for engine protection mask
P.0373 Threshold for high oil temperature
P.0373 Delay for high oil temperature
P.0700 Engine type

To disable: **P.0374=0**

Enabled in: **MAN, AUTO, TEST, REMOTE START**

This protection is enabled only if the controller acquires the measure of the engine lubrication oil temperature. It can acquire it from input T.15 or from any other input configured with the feature AIF.1100 - "VDO oil temperature" or AIF.1101 - "General oil temperature" or even from CAN-BUS (P.0700 other than zero). It is only enabled if the controller has been started by the controller (if the command for the fuel solenoid is activated) and is disabled in the engine start/stop phases. It activates if the temperature is continuously over the threshold P.0373 for time P.0374, but only after the time P.0216 (oil mask) since engine start has elapsed.

55 – Wrong phases sequence



Icon:

Type: **Configurable (Warning/Block/Deactivation)**

Category: **Generator protection**

Related parameters: **P.0101** Number of generator phases
P.0319 Sequence of generator phases (request)
P.0320 Action on incorrect phases sequence

To disable: **P.0319=0**

Enabled in: **MAN, AUTO, TEST, REMOTE START**

It represents the maximum acceptable difference (absolute value) between any of two-phase currents. This protection is only enabled if the system is three-phase and only if the engine has been started by the controller (if the command for the fuel solenoid is activated) and is disabled when the engine is started/stopped. In addition, the generator voltages and frequency must be within the tolerance range and the load must be changed-overt to the mains (it prevents load closing on the genset). Parameter P.0319 allows you to select the phases

frequency required (0=disables feature, 1=clockwise rotation, 2=counter-clockwise rotation, 3=like the mains). The protection activates when the generator rotation direction does not match the one configured, with a 0.5 seconds filter time. When activated, it acts as warning, deactivation or alarm as configured with P.0320.

56 – Low generator voltage

Icon:	
Type:	Warning
Category:	Loads protection
Related parameters:	P.0101 Number of generator phases P.0102 Generator rated voltage P.0202 Hysteresis of generator measures P.0391 Threshold for low voltage P.0392 Delay for low voltage
To disable:	P.0392=0
Enabled in:	MAN, AUTO, TEST, REMOTE START

This protection is only enabled if the controller has been started by the controller (if the command for the fuel solenoid is activated) and is disabled in the engine start/stop phases. In addition, the generator voltages and frequency must be within the tolerance range and the load must be changed-overt to the generator. Threshold P.0391 is expressed as a percentage of the system rated voltage (phase voltage). The protection activates when at least one of the generator voltages continuously lower than the threshold P.0391 for time P.0392.

57 – Clock not valid

Icon:	
Type:	Warning
Category:	General
Related parameters:	P.0418 Weekly test calendar P.0420 Duration of test start P.0421 Weekly work calendar P.0422 Time of work start P.0423 Time of work end
To disable:	-
Enabled in:	MAN, AUTO, TEST, REMOTE START

This warning is always enabled. It activates if the controller detects a not-valid clock status, and functions using the clock are set, such as the weekly test (P.0418 and P.0420) or the operation enabling time (P.0421, P.0422, P.0423). To deactivate it, you need to set the clock.

58 – Low generator frequency

Icon:	
Type:	Warning
Category:	Loads protection
Related parameters:	P.0105 Rated frequency P.0395 Threshold for low frequency (%) P.0396 Delay for low frequency
To disable:	P.0396=0
Enabled in:	MAN, AUTO, TEST, REMOTE START

This protection is only enabled if the controller has been started by the controller (if the command for the fuel solenoid is activated) and is disabled in the engine start/stop phases. In addition, the generator voltages and frequency must be within the tolerance range and the load must be changed-overt to the generator. Threshold P.0395 is expressed as a percentage of the generator rated frequency. The protection activates when the generator frequency drops continuously below threshold P.0395 for time P.0396.

59 – High generator voltage

Icon: 

Type: **Warning**

Category: **Generator/Loads protection**

Related parameters: **P.0101** Number of generator phases
P.0102 Generator rated voltage
P.0202 Hysteresis generator measures
P.0393 Threshold for high voltage (%)
P.0394 Delay for high voltage

To disable: **P.0394=0**

Enabled in: **MAN, AUTO, TEST, REMOTE START**

This protection is only enabled if the controller has been started by the controller (if the command for the fuel solenoid is activated) and is disabled in the engine start/stop phases. In addition, the generator voltages and frequency must be within the tolerance range and the load must be changed-overt to the generator. Threshold P.0393 is expressed as a percentage of the generator rated voltage. The protection activates when at least one of the generator voltages is continuously over the threshold P.0393 for time P.0394.

60 – High generator frequency

Icon: 

Type: **Warning**

Category: **Generator/Loads protection**

Related parameters: **P.0105** Rated frequency
P.0397 Threshold for high frequency (%)
P.0398 Delay for high frequency

To disable: **P.0398=0**

Enabled in: **MAN, AUTO, TEST, REMOTE START**

This protection is only enabled if the controller has been started by the controller (if the command for the fuel solenoid is activated) and is disabled in the engine start/stop phases. In addition, the generator voltages and frequency must be within the tolerance range and the load must be changed-overt to the generator. Threshold P.0397 is expressed as a percentage of the generator rated frequency. The protection activates when the generator frequency rises continuously over threshold P.0397 for time P.0398.

62 – Faulty engine CAN-BUS 0 link

Icon: 

Type: **Configurable (Warning/Block/Deactivation)**

Category: **General**

Related parameters: **P.0700** Engine type
P.0703 Command level via Can-Bus ECU
P.0709 Signalling for Can-Bus ECU failure

Enabled in: **MAN, AUTO, TEST, REMOTE START**

It's enabled only if CAN-BUS is configured (P.0700 other than zero). It is activated when the internal CAN controller switches to BUS-OFF status because of bus communication errors. Parameter P.0709 is used to select the protection type (warning, unloading, interlock).

64 – Fuel pump failure



Icon:

Type: **Warning**

Category: **Fuel pump protection**

Related parameters: **P.0404** Maximum duration of fuel pump activation
P.3001 Function of output 1 or equivalent for the other outputs
P.3201 Equivalent function for DITEL outputs

To disable: **P.0404=0**

Enabled in: **MAN, AUTO, TEST, REMOTE START**

This protection is only enabled if there is an output configured to control the fuel pump (feature DOF.1032 – “Fuel pump” in parameter P.3001 or equivalent for the other outputs) and if a time other than zero has been set in parameter P.0404. It activates if the pump operates continuously for the time set, but the issuance of a warning does not change the pump's operating mode (it turns off the pump, which restarts as soon as the warning is acknowledged).

65 – Low coolant temperature (from analogue sensor)



Icon:

Type: **Warning**

Category: **General**

Related parameters: **P.4025 Function for analogue input 15 (CT)** or equivalent parameter for the other inputs
P.0353 Threshold low cooling temperature (°C)
P.0354 Delay for low cooling temperature
P.0700 Engine type

To disable: **P.0354=0**

Enabled in: **MAN, AUTO, TEST, REMOTE START**

This protection is enabled only if the controller acquires the measure of the engine coolant temperature. It can acquire it from its input (T.15, P.4025 suitably configured) or from CAN-BUS (P.0700 other than zero). It activates if the coolant temperature remains continuously below threshold P.0353 for time P.0354 (even with engine shut down).

95 – AdBlue pump failure



Icon:

Type: **Warning**

Category: **AdBlue pump protection**

Related parameters: **P.1494** Maximum duration of pump activation
P.3001 Function of output 1 or equivalent for the other outputs
P.3201 Equivalent function for DITEL outputs

To disable: **P.1494=0**

Enabled in: **MAN, AUTO, TEST, REMOTE START**

This protection is only enabled if there is an output configured to control the AdBlue fluid pump (feature DOF.1037 – “AdBlue pump” in parameter P.3001 or equivalent for the other outputs) and if a time other than zero has been set in parameter P.1494. It activates if the pump

operates continuously for the time set. The activation of this warning does not change the pump's operating mode (it turns off the pump, which restarts as soon as the warning is acknowledged).

97 – Communication failure with the ECU

Icon: 

Type: **Configurable (Warning/Alarm//Deactivation)**

Category: **General**

Related parameters: **P.1700** Voltage regulator (AVR) type
P.1706 Communication timeout with AVR (s)
P.1707 Action for communication failure with AVR

To disable: **P.1706 = 0**

Enabled in: **MAN, AUTO, TEST, REMOTE START**

It's enabled only if the CAN-BUS connection to the automatic voltage regulator is configured (P.1700). It is activated if the controller does not continuously receive messages from the voltage regulator for time P.1706. With P.1707 the protection is configured as warning, unload, deactivation or alarm.

98 – Communication failure with the ECU

Icon: 

Type: **Configurable (Warning/Alarm//Deactivation)**

Category: **General**

Related parameters: **P.0700** Engine type
P.0709 Signalling for CAN-BUS failure
P.0711 Maximum time without messages from engine

To disable: **P.0711 =0 (no for MTU engine)**

Enabled in: **MAN, AUTO, TEST, REMOTE START**

It's enabled only if CAN-BUS is configured (P.0700 other than zero). For MTU MDEC engines (value from 140 to 147 in parameter P.0700), it is enabled as per specification when the controller does not continuously receive the message NMT ALIVE PDU for the set time. For the other types of engines, it is activated if the controller does not continuously receive messages from the engine for time P.0711. With P.0709 the protection is configured as warning, deactivation or alarm.

99 – Minimum engine speed (from measure, only for DRIVE applications).

Icon: 

Type: **Alarm**

Category: **Engine protection**

Related parameters: **P.0105** Rated frequency (Hz)
P.0105 @ 50Hz Engine's nominal speed (Primary = 1500 rpm)
P.0105 @ 60Hz Engine's nominal speed (Secondary = 1800 rpm)
P.0305 Threshold of minimum speed from engine nominal speed (in %)
P.0306 Delay for minimum speed from engine nominal speed
P.0700 Engine type

To disable: **P.0306=0**

Enabled in: **MAN, AUTO, TEST, REMOTE START**

The protection will be enabled if the controller measures the rotation speed of the engine. The protection is enabled only with the engine running (FUEL solenoid activated) and after the engine speed has been considered "within tolerance". It is disabled during the starting and stopping phase of the engine.

It activates if the acquired speed measure is lower than threshold P.0305 continuously, for time P.0306. P.0305 threshold is expressed in percentage: this percentage is applied to the rated rotation speed of the engine.

105 – Battery charger failure from CAN-BUS

Icon: 

Type: **Warning**

Category: **Engine protection**

Related parameters: **P.0700** Engine type
P.0704 Anomalies deactivation mask from Can-Bus

To disable: **bit 11 of P.0704 on**

Enabled in: **MAN, AUTO, TEST, REMOTE START**

This protection is enabled only if the board is connected to the engine via the CAN BUS (P.0700 different from zero). It is activated when the engine signals the battery-charger alternator failure status over the CAN BUS.

118 – Maximum speed from CAN-BUS

Icon: 

Type: **Alarm**

Category: **Engine protection**

Related parameters: **P.0700** Engine type
P.0704 Anomalies deactivation mask from Can-Bus

To disable: **bit 10 of P.0704 on**

Enabled in: **MAN, AUTO, TEST, REMOTE START**

This protection is enabled only if the board is connected to the engine via the CAN BUS (P.0700 different from zero). It is activated when the engine signals the overspeed state over the CAN-BUS.

132 – High coolant temperature from CAN-BUS

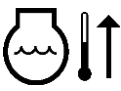
Icon: 

Type: **Warning**

Category: **Engine protection**

Related parameters: **P.0700** Engine type
P.0704 Anomalies deactivation mask from Can-Bus

To disable: **bit 4 of P.0704 on**

Enabled in: **MAN, AUTO, TEST, REMOTE START**

This protection is enabled only if the board is connected to the engine via the CAN BUS (P.0700 different from zero). It is activated when the engine signals the coolant high temperature state over the CAN BUS.

134 – Maximum coolant temperature from CAN-BUS

Icon: 

Type: **Alarm**

Category: **Engine protection**

Related parameters: **P.0700** Engine type
P.0704 Anomalies deactivation mask from Can-Bus

To disable: **bit 5 of P.704 on**

Enabled in: **MAN, AUTO, TEST, REMOTE START**

This protection is enabled only if the board is connected to the engine via the CAN BUS (P.0700 different from zero). It is activated when the engine signals the coolant maximum temperature state over the CAN BUS.

135 – Minimum coolant level from CAN-BUS.

Icon: 

Type: **Alarm**

Category: **Engine protection**

Related parameters: **P.0700** Engine type
P.0704 Anomalies deactivation mask from Can-Bus

To disable: **bit 7 of P.0704 on**

Enabled in: **MAN, AUTO, TEST, REMOTE START**

This protection is enabled only if the board is connected to the engine via the CAN BUS (P.0700 different from zero). It is activated when the engine signals the minimum coolant level state over the CAN BUS

136 – Low coolant level from CAN BUS

Icon: 

Type: **Warning**

Category: **Engine protection**

Related parameters: **P.0700** Engine type
P.0704 Anomalies deactivation mask from Can-Bus

To disable: **bit 6 of P.0704 on**

Enabled in: **MAN, AUTO, TEST, REMOTE START**

This protection is enabled only if the board is connected to the engine via the CAN BUS (P.0700 different from zero). It is activated when the engine signals the low coolant level state over the CAN BUS.

137 – Low battery voltage from CAN BUS

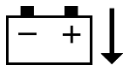
Icon: 

Type: **Warning**

Category: **Engine protection**

Related parameters: **P.0700** Engine type
P.0704 Anomalies deactivation mask from Can-Bus

To disable: **bit 9 of P.0704 on**
 Enabled in: **MAN, AUTO, TEST, REMOTE START**

This protection is enabled only if the board is connected to the engine via the CAN BUS (P.0700 different from zero). It is activated when the engine signals the low battery voltage state over the CAN BUS.

142 – Minimum oil pressure from CAN BUS



Icon:
 Type: **Alarm**
 Category: **Engine protection**
 Related parameters: **P.0700** Engine type
P.0704 Anomalies deactivation mask from Can-Bus
 To disable: **bit 1 of P.704 on**
 Enabled in: **MAN, AUTO, TEST, REMOTE START**

This protection is enabled only if the board is connected to the engine via the CAN BUS (P.0700 different from zero). It is activated when the engine signals the minimum oil pressure state over the CAN BUS.

144 – Low oil pressure from CAN BUS

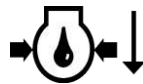

Icon:
 Type: **Warning**
 Category: **Engine protection**
 Related parameters: **P.0700** Engine type
P.0704 Anomalies deactivation mask from Can-Bus
 To disable: **bit 0 of P.0704 on**
 Enabled in: **MAN, AUTO, TEST, REMOTE START**

This protection is enabled only if the board is connected to the engine via the CAN BUS (P.0700 different from zero). It is activated when the engine signals the low oil pressure state over the CAN BUS.

158 – High oil temperature from CAN BUS



Icon:
 Type: **Warning**
 Category: **Engine protection**
 Related parameters: **P.0700** Engine type
P.0704 Anomalies deactivation mask from Can-Bus
 To disable: **bit 2 of P.0704 on**
 Enabled in: **MAN, AUTO, TEST, REMOTE START**

This protection is enabled only if the board is connected to the engine via the CAN BUS (P.0700 different from zero). It is activated when the engine signals the high oil temperature state over the CAN BUS.

159 – Maximum oil temperature from CAN BUS

Icon: 

Type: **Alarm**

Category: **Engine protection**

Related parameters: **P.0700** Engine type
P.0704 Anomalies deactivation mask from Can-Bus

To disable: **bit 3 of P.0704 on**

Enabled in: **MAN, AUTO, TEST, REMOTE START**

This protection is enabled only if the board is connected to the engine via the CAN BUS (P.0700 different from zero). It is activated when the engine signals the maximum oil temperature state over the CAN BUS.

160 – Water in fuel from CAN BUS

Icon: 

Type: **Warning**

Category: **Engine protection**

Related parameters: **P.0700** Engine type
P.0704 Anomalies deactivation mask from Can-Bus

To disable: **bit 8 of P.0704 on**

Enabled in: **MAN, AUTO, TEST, REMOTE START**

This protection is enabled only if the board is connected to the engine via the CAN BUS (P.0700 different from zero). It is activated when the engine signals the water in fuel state over the CAN BUS.

198 – Warnings cumulative – Yellow lamp from CAN-BUS

Icon: 

Type: **Warning**

Category: **Engine protection**

Related parameters: **P.0700** Engine type
P.0704 Anomalies deactivation mask from Can-Bus

To disable: **bit 14 of P.0704 on**

Enabled in: **MAN, AUTO, TEST, REMOTE START**

This protection is enabled only if the board is connected to the engine via the CAN BUS (P.0700 different from zero). It is activated when the engine signals the active state of its yellow lamp over the CAN BUS.

199 – Alarms cumulative – Red lamp from CAN-BUS

Icon: 

Type: **Alarm**

Category: **Engine protection**

Related parameters: **P.0700** Engine type
P.0704 Anomalies deactivation mask from Can-Bus

To disable: **bit 15 of P.0704 on**

Enabled in: **MAN, AUTO, TEST, REMOTE START**

This protection is enabled only if the board is connected to the engine via the CAN BUS (P.0700 different from zero). It is activated when the engine signals the active state of its red lamp over the CAN BUS. Using bit 13 of P.0704 it is possible to configure the protection as warning or alarm.

11 Other functions

11.1 Fuel pump

The device applies full management of the fuel pump, for loading the storage tank into the tank on the machine. The pump can be managed automatically or manually using the controls on the front panel.



From page E.06 (only viewable if an output for the pump command is configured) it is possible to select the pump command mode. To this purpose it is necessary to:

- Press and hold button ▼: the icons that identifies the current mode will be shown in negative.
- Use the vertical scrolling buttons ▲ and ▼ to select the desired mode.
- Confirm keeping button ▼ pressed or cancel the modification pressing and holding ▲.



INFORMATION! the fuel pump control mode is a normal parameter (P.0400) of the controller; therefore, it can be modified including from the programming windows.

The following modes are available:

-  (AUTO): the controller starts/stops the pump depending on the level of the fuel in the tank on board the machine, with a hysteresis band that prevents continuous starts/arrests.
-  (MAN-ON): the pump is stopped only when the tank is full. No hysteresis band is managed: as soon as the tank is no longer full, the pump starts.
-  (MAN-OFF): the pump is always off, even with the tank empty.

Through the parameter P.0406 you can select which of the following is the pump's power supply:



0 – Generator

2 – Loads

3 - Mains

4 - Always powered (power supply is always present).

The controller keeps the pump off if the selected source is not available (maintaining the selected operation mode though). With the controller in **OFF_RESET** the pump is always stopped. The status of the pump is identified by the following symbols:

-  : pump on.
-  : pump off.

The controller is able to operate both with a system for level detection on contacts, and with an analogue tool.

In order for this feature to be usable, the DOF.1032 code – “Fuel pump” must be set in one of the configurable outputs.

Another possibility is to configure a digital output to command and interception solenoid on the pump line (DOF.1034 – “Fuel pump solenoid command”).

In BoardPrg4 we have the menu 4.2.1 for pump configuring. Anyway, you can set each individual parameter directly from the controller.

Parameter P.0405 configures the delay between the activation of the solenoid command (digital output configured as DOF.1034 – “Fuel pump solenoid command”) and the pump start command (digital output configured as DOF.1032 – Fuel pump command”).

11.1.1 Use with an analogue level transducer

To use this function requires:

- It is recommended to have an analogue transducer configured on an analogue input.
- Configure the controller to control the pump in accordance with said transducer (parameter P.0401=0).
- Set at least the thresholds to activate/deactivate the pump (parameters P.0402 and P.0403).
- If set, also minimum, low and high fuel levels are used (parameters P.0347, P.0345, P.0343).

! WARNING: if the first two conditions are met, the controller will control the pump no matter what the threshold values are. In particular, the last condition set thresholds are used even though related operation times are set to zero (for disabling anomalies). Very important is the thresholds setting which should be ranked by level (from down up), as follows: minimum, low, start, stop, high. As already explained, the controller operates even if thresholds are not in this order; all you need is the first three ones lower than the last two ones (within each of the two groups they can be swapped, but it is not recommended).

11.1.2 To use this function requires:

To use this function () it is necessary to:

- Make sure you have a contact level transducer.
- Configure the controller to control the pump in accordance with said transducer (parameter P.0401=1).
- Connect at least the pump start/stop contacts respectively to two configurable inputs of the controller.
- If connected, the minimum, low and high fuel level contacts are also used.

Warning: if the first two conditions are met, the controller will control the pump no matter what the connected contacts are. In particular, the contacts related to the last connection are used even though relevant operation times are set to zero (for disabling anomalies). So, please pay attention to configuration. Last, contacts must match the following pattern: Active after detection of the engine running status, even when it is started manually.

- Minimum level contact (input with feature DIF.4211): closed if the level is below the minimum level threshold.
- Low level contact (input with feature DIF.4212): closed if the level is below the low-level threshold.
- Start-up contact (input with feature DIF.3301) closed if the level is below the pump start-up threshold.
- Stop contact (input with feature DIF.3302) closed if the level is below the pump stop threshold.

- High level contact (input with feature DIF.4213): closed if the level is **over** the pump stop threshold.

11.1.3 Level evaluation

The controller assigns the actual fuel level by calculating in the order all the following evaluations:

- If the level is lower than the pump start threshold, the controller assigns the “start” position.
- If a low-level threshold exists, and the level is lower than threshold, the controller assigns the “low” position.
- If a minimum level threshold exists, and the level is lower than the threshold, the controller assigns the “minimum” position.
- If the level is higher than the stop threshold, the controller assigns the “stop” position.
- If a maximum level threshold exists, and the level is higher than the threshold, the controller assigns the “maximum” position.
- If none of the previous condition is met, the controller assigns the “hysteresis” position.

11.1.4 Automatic pump control

Basically, if you want to reverse the logic of an output you need to add the corresponding value into its parameter:

- Activates if the level is “start”, “low” or “minimum”.
- Deactivates if the level is “stop” or “maximum”.
- Retains the actual command if in “hysteresis”.

11.1.5 Manual pump control

Pump can be activated and deactivated according to operator needs. However, the controller prevents the start if the level (see previous paragraphs) is “stop” or “maximum”.

11.1.6 Protections

Moreover, you can set the maximum fuel pump activation time with parameter P.0404. This parameter should be used to set the time needed for the pump to fill the equipment tank, in the worst conditions: empty tank and engine started at maximum power. If the pump remains operational (either manually or automatically) for more then said time, the controller stops it (without changing the control mode), and issues warning W064: probable pump failure or pump not sucking from the storage tank. As soon as the alarm is acknowledged by the operator, the pump restarts.

In many cases you need to be able to block the pump (with a signal on the display) due to certain situations of the system, such as when the storage tank is empty. In these case you need to:

- Configure a digital input of the controller with feature DIF.4051 – “Fuel pump warning” (in parameter P.2001 or equivalents).
- Associate a delay to that input (in parameter P.2002 or in the equivalent parameters).

If the input remains active for the time configured, the controller issues a warning and stops the pump (without changing the command mode).

11.2 Load thresholds

This function must not be mismatched with the “Load function” available for the parallel systems described in the “Parallel functions handbook”.

This function allows to monitor the trend of the active power in order to diagnose:

- A low load condition
- A high load condition, to disconnect, in case, a part of the loads.

It is necessary to choose a priori the condition to be monitored (using the P.0481 parameter: set it to zero to select the low power monitoring, set it to 1 to select the high-power monitoring).

“0-Low power” is selected by default, but with a 0% reaction threshold, so the feature is disabled.

In some cases, it is useful to deactivate the function when not needed. In these cases, you need to configure a digital input with feature DIF.2703 – “Enable the loading thresholds” in parameters P.2001 or equivalents. If such an input already exists, the feature is enabled only when it is “active”.

11.2.1 Low load

The purpose of this function is to diagnose a low power condition (low load) and communicating the problem through one of the controller's digital outputs (with more gensets in parallel this output could be used to deactivate some of the gensets). To associate an output to this function, the code DOF.3121 – “Load thresholds” must be configured in the parameter P.3001 (or the corresponding parameter for the other outputs). If no output is configured in this way, the function will not work.

The controller watches the total active power delivered by the generator, comparing it to two thresholds (which set, therefore, a hysteresis band): the output is activated (therefore signalling the low power condition) if the power stays below the lower threshold for the set time. In the same way, the output is disabled if the power rises above the upper threshold for the set time. These thresholds and delays are set with following parameters:

- P.0483: lower threshold (percentage of the rated power P.0125).
- P.0484: delay associated to the lower threshold (in seconds).
- P.0485: higher threshold (percentage of the rated power P.0125).
- P.0486: delay associated to the higher threshold (in seconds).

If the thresholds P.0483 and P.0485 are set to zero or are not congruent, the function will be disabled.

From the moment the contact of DIF.2703 - “Enable load thresholds” (if any) is activated, a timing begins (the length of which is configured with parameter P.0482), during which the output is maintained low regardless of the power. This time allows the system to stabilize before starting to watch powers.

11.2.2 High load

Purpose of this function is to diagnose a high-power status (high load) to disconnect part of the less important loads. Everything we said in the previous paragraph applies, though taking into account that the output is activated if the power exceeds threshold P.0485 and deactivated when the power drops below threshold P.0483.

The output is activated in a maximum power condition, and can directly be used as control for disconnecting loads. Ensure to pay attention to the thresholds: when a part of the loads is disconnected, the power will decrease. If the lower threshold is too high, the output will be disabled, and this could cause the load to be reconnected, with a pendulum effect.

11.3 Alternative parameters configuration

You can use certain properly configured digital inputs to change the configuration of the system without changing the programming parameters. In fact, the controller manages internally four groups of alternative parameters that can be “copied” in the operating parameters on request (through a dedicated digital input).

Alternative configurations can be programmed only using the BoardPrg4xx.

You cannot program or modify the configurations from the controller.

The parameters present in each alternative group are the following:

- P.0101: Generator number of phases.
- P.0102: Generator nominal voltage
- P.0105: Generator nominal frequency.
- P.0106: Generator nominal power (kVA).
- P.0107: CT primary for generator/load.
- P.0116: Mains nominal voltage
- P.0119: Mains phases number.
- P.0125: Engine nominal power (kW).
- P.0128: Is the neutral of the generator connected to the controller?
- P.0129: Is the mains neutral connected to the controller?
- P.0713: Speed at 0% command
- P.0714: Speed at 100% command
- P.1703: Voltage corresponding to 0%.
- P.1704: Voltage corresponding to 100%.

It is possible to change the configuration by means the following input digital functions:

- DIF.2151 – “Select configuration 1”. When the input becomes "active", parameters of alternative configuration set 1 are copied in the working configuration.
- DIF.2152 – “Select configuration 2”. When the input becomes "active", parameters of alternative configuration set 2 are copied in the working configuration.

Remark: copying an alternative set into the working configuration causes the loss of the previous loaded parameters. The only way to restore them is to have them stored in another alternative configuration and recall it.

This function is usually used with multiple-voltage and/or multiple-frequency panels: wiring the cams of a selector to the panel on the inputs of the controller, you can manually switch voltages and frequency without having to use the parameters of the controller.

 INFORMATION! parameter change occurs only with engine idle and with the controller in OFF_RESET.

Among the various parameters used in the alternative configurations, there is also the engine speed. For some CAN-BUS engines (such as the Volvo engines), the engine speed can be controlled directly from the controller, by means of the P.0701 parameter (and consequently it can be done using the alternative configurations). Refer to [4] for gear shift, because the operation is more complex.

11.4 EJP function

 **ATTENTION!** the controller is unable to directly track EJP information from the mains. In order to use this function, an external detector should be used. This detector must provide two output signals coherent with said function.

The EJP function allows to start the engine and warm it before mains failure, so when it will happen, loads can be immediately changed-over on gen-set, reducing to the minimum the time the loads remain not supplied.

The system is based on two signals, available through the mains provider:

- A. A signal activated well in advance with respect to the mains failure (e.g., approx. 30 mins).
- B. A signal activated just before mains failure.

We want to start the engine in (a settable) advance in relation to signal B; however, the load must be taken only when B is active. The controller can perform this operation following the steps below:

- A and B signals must remain active until mains reactivates.
- Both signals must be connected to relays with exchanging contacts.
- The time between A and B signals activation must be known.

To use this function the controller has to be configured in the following way:

- Configure a digital input with feature DIF.2701 – “Remote start request” (in parameter P.2001 or the equivalents for the other inputs). In addition, this input requires configuring the engine start-up delay (in seconds, in the parameter P.2002 or equivalent), since A activates. If, for example, we want to warm the engine for five minutes and the A signal will activate 30 minutes before B, it will require to set 1500 seconds, i.e., 25 minutes (it is possible to set delays up to 4000 seconds, i.e., 66 minutes).
- Configure a second digital input with feature DIF.2502 – “Loading inhibition) (in parameter P.2004 or the equivalents).

Then connect the NO contact of signal A to first configured input and the contact NC of signal B to second input.

 **ATTENTION!** The feature “Loading inhibition” blocks the load connection, even if the genset has been started automatically for other reasons. To prevent this problem, use a logic that prevents the activation of this feature if the generator was not started with the “REMOTE START” feature.

When both signals are inactive, the controller does not receive the remote start request and remains at rest in AUTO mode. The "Inhibition of supply" contact is skipped.

When signal A activates, both controller inputs will be active. The controller will not immediately shift to **REMOTE START** mode, but will do only after the time set in P.2002 (or equivalents) is elapsed. So, also in this phase the CHANGE-OVER INHIBITION is skipped. In this phase, window S.01 shows the remaining time to start-up.

After the time since activation of signal A, the controller shifts to REMOTE START mode and performs the engine start. But in this phase, the “Change-over sequence disabling” input is no longer skipped, and, being it active (connected on contact NC), it prevents the loads change-over on generator.

When signal B activates, the “Change-over sequence disabling” input deactivates, thus allowing the load change-over on generator.

When the mains is on, both signals A and B deactivate. Therefore, the controller reverts to AUTO mode, due to mains on, performs the engine stop (with cooling cycle).

11.5 Maintenance

The controller can automatically inform the operator about programmed maintenance, by means of an engine hours counter.

11.5.1 Service hours counter

This function is configurable with parameters P.0424 and P.0425. With P.0424, it is possible to set extra operation hours for maintenance service. Instead, P.0425 is used to configure what type of warning should be issued at expiry: a warning, an unloading or an interlock (the anomaly code is A039 or U039 or W039).

The function is enabled if the parameter P.0424 contains a value other than zero. The count starts in the moment this parameter is set. When the time configured has elapsed, the controller stores the status of the service request in the non-volatile memory. In this way, also powering the controller off, signalling is not lost and cannot be reset. If an alarm has been selected with P.0425 then the generator cannot be used again. This function allows to manage rental contracts “by hour number”.

To cancel the maintenance request (and the relevant signal) requires setting again the parameter P.0424: to disable the function, set the parameter to zero; to set the next maintenance after the same period as the previous one, simply confirm the existing parameter; or set a new interval.

Installer level password is required for these parameters.

11.6 Counters

The controller manages internally the following counters:

1. Partial active power meter (kWh) (resettable), with power measured when the loads are connected to the generator; it measures only the supplied power and does not measure in case of power reverse.
2. Load working time with GCB closed (hours) counter (resettable to zero) Total active power meter (kWh), with power measured when the loads are connected to the generator; it measures only the supplied power and does not measure in case of power reverse.
3. Partial reactive power meter (kvarh) (resettable), with power measured when the loads are connected to the generator: it measures the absolute value.
4. Total reactive power meter (kvarh), with power measured when the loads are connected to the generator: it measures the absolute value.
5. Engine starts counter (resettable to zero).
6. Partial engine running hours counter (resettable to zero).
7. Total counter of the controller supplying hours
8. Counter for the total engine running hours left to maintenance.
9. Load working time with GCB closed (hours) counter (resettable to zero)
10. Controller total power supply time (hours) counter

Almost all these counters and meters are displayed on the controller's front panel (only the total supply time counter is not displayed). However, all can be read via the serial port (with the Modbus protocol). Some of these counters can be reset by the operator following a proper procedure, or via the serial port (they are marked in the list with “resettable to zero”). All these counters are saved in a non-volatile memory; therefore, they store their values also when the controller is powered off. Since non-volatile memories “consume” themselves writing in them, it is necessary to reduce at the minimum the number of writings. For this reason, a counter is not immediately saved as its value changes, and it is then important to know when values are saved and how to be sure that they are saved before removing supply from the board.

Counters are saved (all together and in the same time) in the following conditions:

- Immediately after each engine start (with engine running, not after each start attempt).
- Immediately after each engine stop (when controller acknowledges the engine stopped status, not when stop is requested).
- After each engine running hours counter increase (total, also if the engine has been started for instance six times for ten minutes each time).
- After each total engine running hours counter increase (total, also if the engine has been started for instance six times for ten minutes each time).
- Each time the load engine working hours counter is increased (total, also if the engine has been started for instance six times for ten minutes each time).
- Each time the operating mode is switched to **OFF_RESET**.
- For each hour the controller is powered.
- When parameter P.0424 is changed (maintenance interval).

Furthermore, counters are saved when they are reset to zero (individually or globally) via front panel or serial port. Note that some counters have a decimal part (for example the minutes-counters associated to hours-counters), which is also saved in a non-volatile memory. Powering off the controller in an uncontrolled way can cause the loss of the decimal part. It is enough to switch the controller to OFF-RESET to force data saving, before switching off the power.

11.6.1 Counters reset

The resetting procedure is common for all the counters, but it only applies to some of them, based on the page displayed on the multifunctional display. See in paragraph 7.4.8.3 the description of the display page that contains the counter to be reset to zero.

11.7 Clock

The board is provided with a hardware clock. It is shown in detail in the page S.03. It can be set through the programming menu 4.7.1 – Date/Time or the USB, and is used for many functions:

- History logs recordings.
- Engine TEST start-up weekly planning.
- Weekly planning of time intervals in which the gen-set can start automatically.

11.7.1 Engine TEST start-up weekly planning.

The engine TEST start-up is planned on a weekly basis. Thus, it is possible to select in which days the engine must be started for TEST.

 **ATTENTION!** Periodical test start-up is not linked to manual or auto engine starts.

I.e., the engine may have been used just few minutes before but test will anyway start at due time. In addition to the dates, it is also possible to select a start time and duration. This time interval is common to all the days selected.

The parameters related to this function are the following:

- P.0418: allows to specify in which days of week the engine TEST will be performed. It is a bit-configurable parameter; each bit of the parameter corresponds to a day of the week. The value you must set for the parameter is the sum of the value field of the following table for the days needed.

Bit	Value	Day
0	1	Sunday
1	2	Monday
2	4	Tuesday
3	8	Wednesday
4	16	Thursday
5	32	Friday
6	64	Saturday

For example, if you want to perform the TEST only on Monday and Thursday, you must set 18 (16+2).

- P.0419: allows to set start time for the TEST (Hours and minutes).
- P.0420: allows to configure the TEST duration (in minutes).

P.0420 sets the duration instead of an end test time.

11.7.2 Weekly scheduling of engine operating time intervals.

In some applications, it is useful to inhibit the automatic intervention of the engine for mains failure in hours or days where the mains is not used. For example, if a factory is closed on Sunday, the engine should never start in this day for mains fault (because it consumes unnecessary fuel). With this function you can select in which days and in which time intervals the gen-set can start automatically. The planning is made on a weekly basis: therefore, it is possible to plan in which days the generator must operate. Besides days, it is possible to set a single auto operation enable time slot common to all selected days.

The parameters related to this function are the following:

- P.0421: allows to specify in which days of week the engine can start automatically. It is a bit-configurable parameter; each bit of the parameter corresponds to a day of the week. The value to be set for the parameter is the sum of the value fields in the following table related to the days needed.

Bit	Value	Day
0	1	Sunday
1	2	Monday
2	4	Tuesday
3	8	Wednesday
4	16	Thursday
5	32	Friday
6	64	Saturday

- P.0422: allows to configure the start of the time interval during which the engine can start automatically (in hours and minutes).

- P.0423: allows to configure the end of the time interval during which the engine can start automatically (in hours and minutes).

Usually, P.0422 will be set to a value lower than P.0423. On the contrary, if it contains a higher value, the controller infers that the time interval is set across midnight: in this case, the time set with P.0422 refers to the days selected with P.0421, while the time set with P.0423 refers to the following days.

For example, in case an automatic gen-set start is required only Monday through Friday, between 08:00 and 18:00, you must set:

P.0421 = 62 (2+4+8+16+32)

P.0422 = 08:00

P.0423 = 18:00

11.8 Non-volatile memory

The controller has a non-volatile memory inside (which does not need power), used to store various information such as parameters, counters etc. The memory is divided into different zones. When the controller is powered, it performs a check on the data stored in each area: if even just one area is incorrect, it displays an error message; this can happen after a FW update. Said message contains a numerical code (in hexadecimal form); each bit to 1 of said code corresponds to an area of the memory that is not valid. Here is a table listing the areas and their bit.

Area	Version	Bit	Value	Description
1	1.00	0	1 (0001)	Coefficients for the calibration of the measuring inputs of the controller.
2	1.00	1	2 (0002)	Different information (lcd display contrast, maintenance request).
3	1.00	2	4 (0004)	Counters
4	1.00	3	8 (0008)	History log for diagnose codes acquired via CAN-BUS from the engine.
5	1.00	4	16 (0010)	Reserved.
6	1.00	5	32 (0020)	Parameters alternative configurations.
7	1.00	6	64 (0040)	Parameter:

If, for example, the value between brackets is "0004", it means that only the counters area is not valid. If the value is "0041", it means that the parameters areas (0040) and the LCD contrast areas (0001) are not valid.

If any zone is not valid, the normal operation sequences are not performed until when the operator presses buttons "AUTO + STOP": it is in effect necessary that the situation has been acknowledged as it can cause dysfunctions (for example if the not valid area is the one of the parameters). Only when the operator presses "AUTO + STOP", the controller reloads the defaults for the data saved in the not valid areas: this means that if the controller is shut down without pressing "AUTO + STOP", when you turn it on next you will get again the signalling of not valid memory.

11.9 Plant name

It is possible to assign a name to the plant, including it into parameter P.0456.

11.10 Power saving mode

This mode is useful in Auto Start applications to limit the consumption from the starter battery when the battery chargers are disconnected. The controller switches off and minimizes the power consumption. To enable power saving mode, set parameter P.0590 " Delay before energy saving" to a value other than zero.

To enable the mode, you must:

- Turn off the engine;
- Disconnect any ongoing communications via USB (e.g., with BoardPrg4);
- Set the controller to OFF-RESET;
- Press the emergency button (if configured on any digital input).

After the time configured in P.0590, the device automatically activates power saving and the LCD display and all the lights go off. You can also manually force this mode by pressing and holding the **STOP** button for at least 5 seconds. The activation of the energy saving mode with relative date and time is recorded in the event store, if enabled by the bit 0 of parameter P.0441.

It is possible to quit this mode, in two ways:

- by pressing the **START** key;
- on **T.17** digital input status change.

The **T.17** digital input, to quit the energy saving mode, is only available from board revision 1 and later (E611215610001). Using parameter P.0599 is possible to select the required status change of T.17:

- "0-Disabled": digital input is not used to quit energy saving mode;
- "1-Rising edge": on digital input activation;
- "2-Falling edge": on digital input deactivation;
- "3-Both edges": on digital input activation and deactivation.

The deactivation of the energy saving mode with relative date and time is recorded in the event store, if enabled by the bit 0 of parameter P.0441.

11.11 CAN-BUS connection with the ECU of the engines

GC250 has a CAN-BUS interface dedicated to interfacing with electronic motors (CAN0). See documents [5] [6] for detailed information. To activate the connection, you must first select the type of ECU via parameter P.0700 (from the list of supported ones). If the desired ECU is not in the list, by setting the value 300 in P.0700 it is possible to download an external file that describes the communication with the ECU. This operation requires the BoardPrg4 software, which allows you to select the ECU from the list of all those for which MECC ALTE has developed a configuration file.

It is then possible to decide whether to receive information only from the engine ECU or whether to also send commands (P.0703, described in the documents mentioned above): by setting P.0703 to "0", GC250 does not transmit anything on the CAN-BUS. Finally, it is possible to set a maximum time using parameter P.0711: GC250 will activate an anomaly if it does not receive messages from the engine ECU for this time.

If P.0703 is set to a value greater than 90, GC250 is able to control the engine speed. To do this, parameter P.0702 is used, which allows you to set a value of 0...100%, where 50% corresponds to the rated speed (1500 rpm @ 50 Hz, 1800 rpm @ 60 Hz). From version 1.09, GC250 also provides the parameters P.0713 and P.0714, which allow to indicate respectively the speeds corresponding to command values of 0% and 100%.

11.12 CAN-BUS connection with voltage regulators (AVR)

With the same CAN-BUS interface described in the previous paragraph, GC250 allows interfacing with automatic voltage regulators (AVR). To activate the connection, you must first download an external file that describes the communication with the controller. This operation requires the BoardPrg4 software, which allows you to select the AVR from the list of all those for which MECC ALTE has developed a configuration file.

It is then possible to decide whether to receive information only from the voltage regulator or whether to also send commands (P.1701): by setting P.1701 to "0", GC250 does not transmit anything on the CAN-BUS.

Parameter P.1702 allows you to specify which address GC250 should use when sending messages to the voltage regulator on the CAN-BUS interface: for some regulators it is not used (already defined in the configuration file), but for others (for example in the generic file J1939-75) it allows you to easily adapt the generic management of GC250 to the requirements of the specific voltage regulator.

If P.0701 is set to a value greater than 90, the GC250 is able to control the generator voltage. To do this, parameter P.1705 is used, which allows you to set a value of 0...100%. Parameters P.1704 and P.1705 allow to indicate the voltages corresponding to the commands 0% and 100% (by default 360Vac and 440Vac). Therefore, with the default configuration (P.1705 = 50%, P.1703 = 360Vac and P.1704 = 440 Vac) GC250 will regulate the generator voltage at 400 Vac.



GC250 also allows you to modify some setpoints of the voltage regulator (obviously if the regulator itself supports this possibility). Parameters P.1721...P.1728 are automatically displayed or hidden (on both GC250 and BoardPrg4) depending on whether the voltage regulator supports changing setpoints or not.

Finally, with parameters P.1706 and P.1707 it is possible to configure GC250 to activate an anomaly (warning, deactivation or alarm) if it loses the CAN BUS communication with the voltage regulator.

11.13 Pump for AdBlue fluid

The controller implements a complete management of the pump for refilling the AdBlue liquid from the external storage tank into the daily tank. Pump management includes automatic operation and manual controls, accessible from the front panel.

There are three modes of operation of the pump:

-  AUTO: the pump is started/stopped by the controller according to the level of the AdBlue fluid in the daily tank, with a hysteresis band that prevents continuous starts/stops.
-  MAN-ON: the pump is stopped only when the tank is full. No hysteresis band is managed: as soon as the tank is no longer full, the pump starts.
-  MAN-OFF: the pump is always off, even when the tank is empty.



The operating mode can be selected in two ways:

- By modifying parameter P.1490 ("AdBlue pump mode").
- From display page E.25 (visible only if one digital output is configured for pump control) it is possible to use the normal setting procedure:
 - Press and hold the ▼ button: the icons that identify the current mode will be displayed in reverse.
 - use the vertical scroll buttons ▲ and ▼ to select the desired mode.
 - confirm by keeping the ▼ button pressed or cancel the modification by keeping ▲ pressed.

Through parameter P.1496 it is possible to select which is the power source of the pump between:

- 0 – Generator
- 2 – Loads
- 3 – Mains
- 4 – Always powered (power supply is always present).

The status of the pump is identified by the following symbols:

-  : pump on.
-  : pump off

The controller keeps the pump off if the selected power source is not available (while maintaining the selected operating mode). With the controller in OFF_RESET mode, the pump is always stopped.

The controller can work both with a contact level detection system and with an analogue level measurement.

To use this function, the code DOF.1037 - " AdBlue pump" must be selected for one of the configurable outputs of the controller.

It is also possible to configure a digital output to control an interception solenoid valve on the pump line (DOF.1038 - "Solenoid valve for the AdBlue pump"). Parameter P.1495 configures the delay between the activation of the solenoid valve command and the pump start command.

In BoardPrg4 there is menu 4.2.4 for pump configuration. However, it is possible to set the individual parameters by acting directly on the controller.

11.13.1 Using an analogue level measurement

To use this function:

- The level measurement is acquired via Canbus by the engine control unit (SPN 1761 - SAE J1939). The ECU must therefore provide this measure.
- The contacts for the level must not be configured (see next paragraph), otherwise the controller uses those.
- At least the thresholds for activating and deactivating the pump must be properly configured (parameters P.1492 and P.1493).

Check that the activation threshold (P.1492) is lower than the deactivation threshold (P.1493).

11.13.2 Using a contact level transducer

To use this function:

- The contact level transducer must exist.
- The start and stop contacts for the pump must be connected to two configurable inputs of the controller.

Contacts must respect the following convention:

- Start contact (input with function DIF.3311): closed if level below the start threshold of the pump.
- Stop contact (input with function DIF.3312): closed if level below the pump stop threshold.

11.13.3 Evaluation of the level

The controller assigns the current position of the AdBlue fluid level by evaluating the following conditions in order:

- If the level is below the pump start threshold, assign the "start" position.
- If the level is higher than the pump stop threshold, assign the "stop" position.
- If none of the above conditions are met, assign the "Hysteresis" position.

11.13.4 Automatic pump control

With reference to the position evaluated in the previous paragraph, the pump is:

- Activated if the level position is "start".
- Deactivated if the position is "stop".
- Maintains the current command if the position is "hysteresis".

11.13.5 Manual pump control

The pump can be activated and deactivated as required by the operator. However, the controller prevents starting if the level position (see previous paragraphs) is "stop".

11.13.6 Protections

Using parameter P.1494 it is possible to set the maximum activation time for the pump. It should be configured with the maximum refilling time, in the worst conditions. If the pump remains running (both in manual or automatic mode) for longer than this, the controller stops it (without changing the control mode) and activates the pre-alarm W095: probably there is a fault in the pump or in any case the pump is not drawing from the storage tank. As soon as the alarm is acknowledged by the operator, the pump restarts.

11.13.7 Signalling

The controller makes available the internal commands for the pump and the solenoid valve in two internal states (usable in AND / OR logics):

- ST.139: pump command.
- ST.140: command of the solenoid valve.

In addition, the activation and deactivation of the pump are recorded in the event log if bit 7 of parameter P.0441 is active:

- EVT.1072: pump activated.
- EVT.1073: pump deactivated.



**This document is owned by MECC ALTE. All rights reserved.
All rights reserved. MECC ALTE reserves the right to modify this document without prior notice.
MECC ALTE has made any effort to ensure that the information herein provide are correct; in any
case MECC ALTE does not assume any liability for the use this information.
The disclosure by any means of this document to third parties is not allowed.**

Mecc Alte SpA

Via Roma, 20
36051 Creazzo, Vicenza - ITALY
Tel. +39 0444 396111
Fax. +39 0444 396166
Email: info@meccalte.it
www.meccalte.com